

서은플랜트기술(주)

SEOEUN PLANT TECH

설계, 인증, 컨설팅 모두 가능한 토탈엔지니어링회사
석유 · 정밀화학, 바이오, 제약, 식품, 신소재, 에너지환경분야,
고사양 장치류(압력용기, 열교환기, 타워, 저장조),
PILOT PLANT, TEST BED, 국가정책R&D연구과제 등

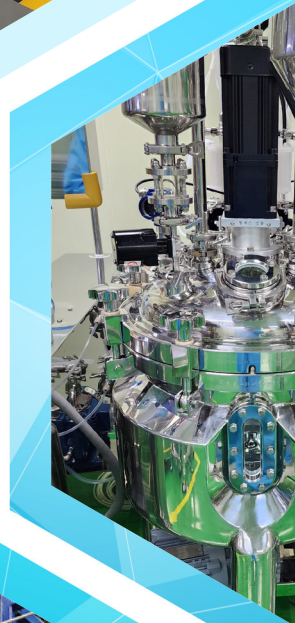

서은플랜트기술(주)
SEOEUN PLANT TECH CO., LTD.

문의전화 010-7760-6176 / 010-5796-2389 대표전화 031-703-0480

홈페이지 www.seplant.com 이메일 septech@septech.co.kr

팩스 031-703-0481 공식블로그 blog.naver.com/septech

SEOEUN

PLANT TECH

회사소개

About Company

서은플랜트기술 주식회사는 석유화학 및 정밀 화학, 바이오, 제약, 식품, 신소재, 에너지 환경분야의 설계 및 국내외 인증, 컨설팅, 제작지원 등 산·학·연·관·군을 아우르는 토탈엔지니어링 회사로서, 고객의 요구사항을 ONE STOP으로 해결해 드립니다.

또한 저희 서은플랜트기술(주)은 약 40년간 축적된 노하우와 신뢰를 토대로, 저희 회사를 이용한 고객이 국내는 물론 해외 모든 시장에서 인정받을 수 있도록 최선을 다하고 있습니다. 감사합니다.

- 임직원 일동 -

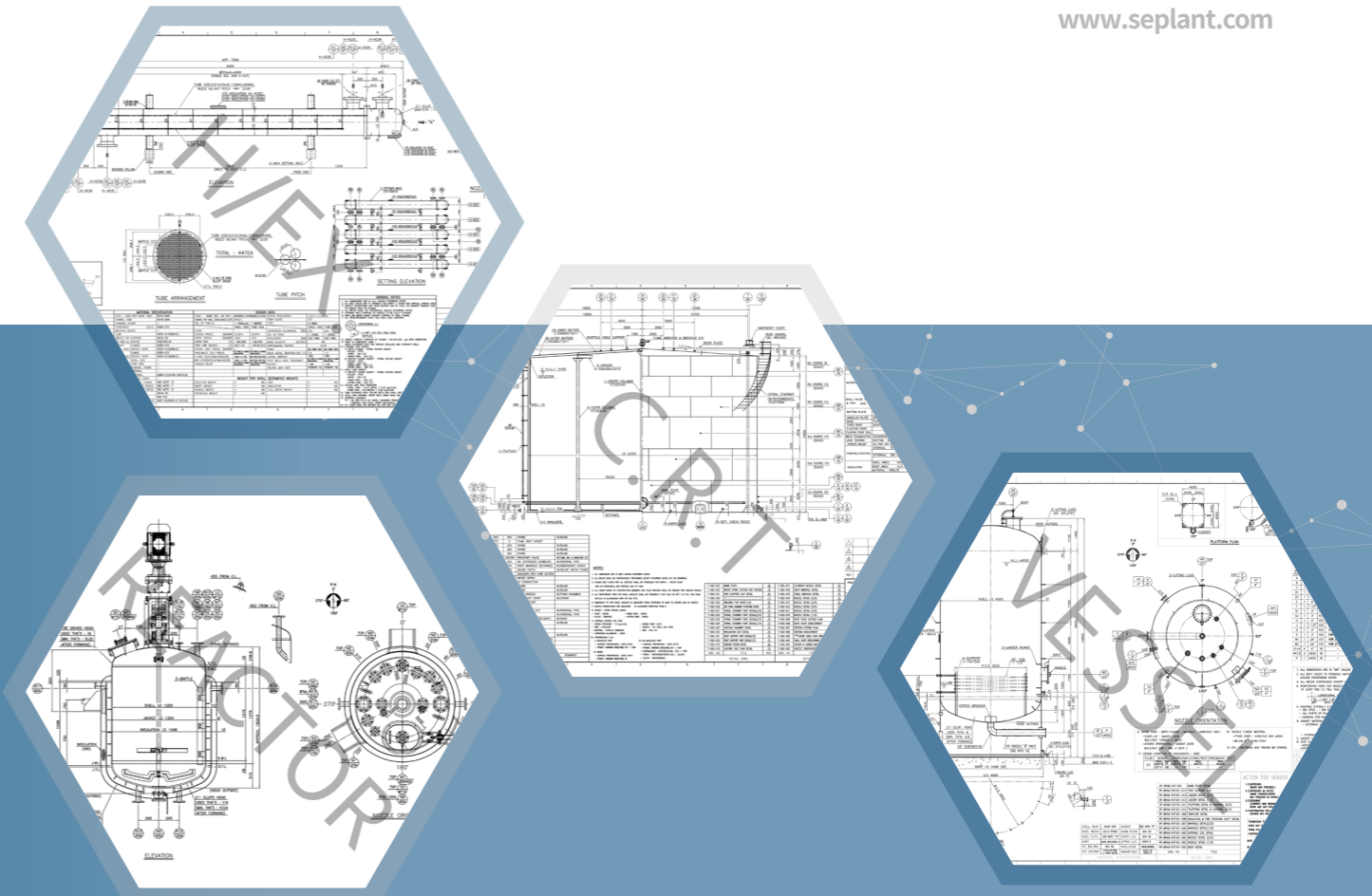

목차

contents

- 회사소개
- 설계범위
- 설계(DESIGN)
 - 1) 도면 및 각종 계산
 - ① 압력용기 등 장치류
 - ② 강도계산 / 열계산 /유한요소해석(FEA) / 구조계산
 - 2) TOTAL ENGINEERING(공정/기계/전기)
 - ① PLANT 엔지니어링(석유화학/바이오/식품/에너지)
 - ② PILOT 엔지니어링
- 인증(CERTIFICATION)
 - 1) 국내품 인증
 - 2) 수입품 인증
 - 3) 선급품 인증
 - 4) 기타 검사 인증대행
- 컨설팅(CONSULTING)
 - 1) 설계교육(ASME / KS / JIS / API)
 - 2) 국내품 / 수입품 검사 과정 교육
 - 3) 견적지원 / 법규검토
 - 4) 제작지원
- 테스트베드(TEST BED)
- 스페셜 제작 프로젝트(SPECIAL MANUFACTURE PROJECT)
- 기업주요실적(PROJECT REFERENCES)

연혁

History

- 1998** • 서은 엔지니어링 설립
(사업분야 : 각종 석유화학 장치류, 기본설계 및 상세설계)
- 2002** • MECAL V2.0 강도계산 프로그램 개발(ASME CODE)
- 2005** • MECAL V3.0 강도계산 프로그램 NEW 버전 출시 (ASME CODE)
- 2008** • 다양한 장치설계 프로그램 구매완료
• 사업 영역 확장 : 열계산, 배관, 공정, 구조물 설계
- 2011** • 사업 영역 확장 : 국내 압력용기 인증 검사대행 (KOSHA, KEA, KGS, 소방법)
- 2013** • 사업 영역 확장 : 선급 압력용기 설계인증 검사대행 (KR, ABS, DNV, GL, LR, RINA)
- 2014** • 서은플랜트기술(주) 법인으로 재도약
• 사업 영역 확장:KEA, KOSHA, KGS 해외 인증 검사 대행
- 2015** • MIDAS GEN 프로그램 적용(특이 형상 구조물 응력 해석)
• 사업 영역 확장 : 공정설계, 기계 장치, 전기, 계장 등 토탈 엔지니어링 시작
- 2017** • 사업 영역 확장 : 한국에너지공단(KEA)수입 압력용기 검사 대행 시작 (KOSHA, KGS etc.)
- 2018** • JIS강도계산 프로그램 개발 및 적용(JIS B8265~8267)
• 고사양의 고온고압 스페셜 장치류 제작지원
- 2020** • 사업 영역 확장 : 국내 최초 테스트베드 개념 도입 및 설계 실시
- 2022** • PILOT PLANT, 테스트베드 등 실험설비 제작 및 조건별 테스트실 확장이전 완료
- 2024** • 분당본사 및 보은지점 확장이전 완료
• 해외 수입용기 인증 및 검사대행 누적 2500건 달성
- 2025** • 한국산업기술진흥협회로부터 연구개발전담부서 인정
- 2026** • 국내 설계 관련 세계 유일 프로그램 개발 착수(진행중)
• 특허권 소유 원년의 해(보유 1건/출원 중 2건/다수 대기 중)

설계범위 Design Scope



설계범위

- ① 석유 · 정밀 화학 / 바이오 / 제약 / 식품 / 신소재 / 에너지 환경 등 각 분야에 사용되는 압력을 받는 용기등의 모든 장치류
- ② PILOT PLANT, TEST BED, R&D연구과제
- ③ 고객이 요청하는 업무 범위의 종류

- 01 견적 단계 참여 (개발 / 신규 / 증설 / 보수 등)
- 02 설계만 원하시는 경우 (도면 / 강도계산 / 구조계산 / 열계산 / PFD / P&ID / PIPING)
- 03 인증만 원하시는 경우 (한국산업안전보건공단 / 한국에너지공단 / 한국가스안전공사 등)
- 04 설계 + 인증 원하시는 경우
- 05 설계 + 인증 + 제작지원 원하시는 경우
- 06 컨설팅(설계교육 / 검사교육 / 법규검토) 원하시는 경우

* PILOT PLANT / TEST BED / R&D 는 5)항대로 진행하시는것이 좋습니다.

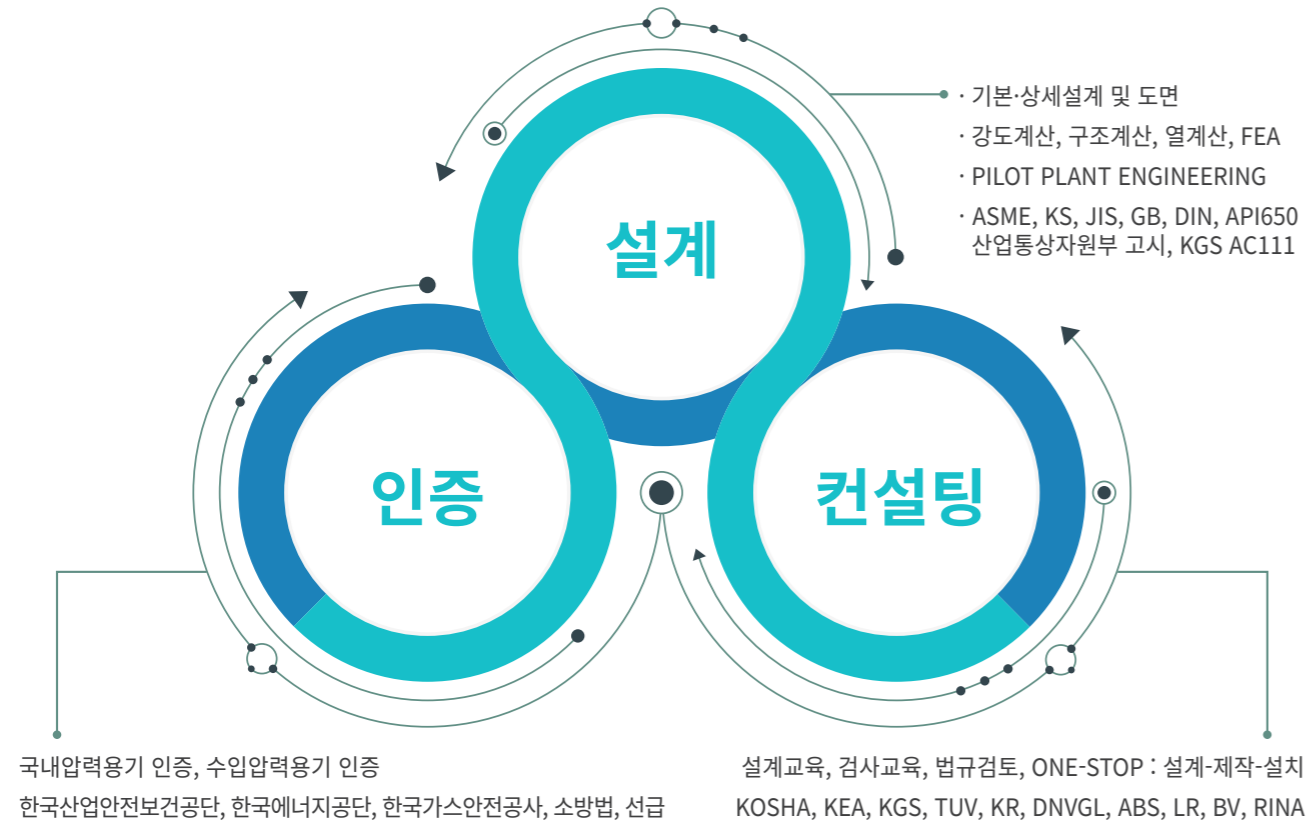

설계대상 Design Target



설계대상

증발 흡수 증류 건조 흡착 등의 공정에 필요한 유체를 저장 분리 이송 혼합 등에 사용되는 압력용기 또는 그 전체 공정설비 등의 PILOT 엔지니어링

설계 장치류

압력용기 / 저장탱크 / 열교환기 / 타워 / 반응기 / 교반기 / 바이오 탱크 / 에어헤더 / 스팀헤더 고압가스 용기 / 오토클레이브 / 레토르트 / 살균기 / 멸균기 / 염색기 / 리시버 탱크 / 스팀롤러 추출기 / 증류기 / 건조기 / 배양기 / 탈기 / 고압가스 용기 / 어류몰레이터 / 후레쉬탱크 / 증발기



설계도면 Design Drawing

■ 압력용기- 기본 / 상세 설계
VESSEL / REACTOR / H/EX. / AUTOCLAVE / TOWER / C.R.T /
FILTER HOUSING / SILO / AIR HEADER 등 설계대상(상기내용
참조)에 포함된 모든 압력용기에 대한 도면 작성이 가능합니다.

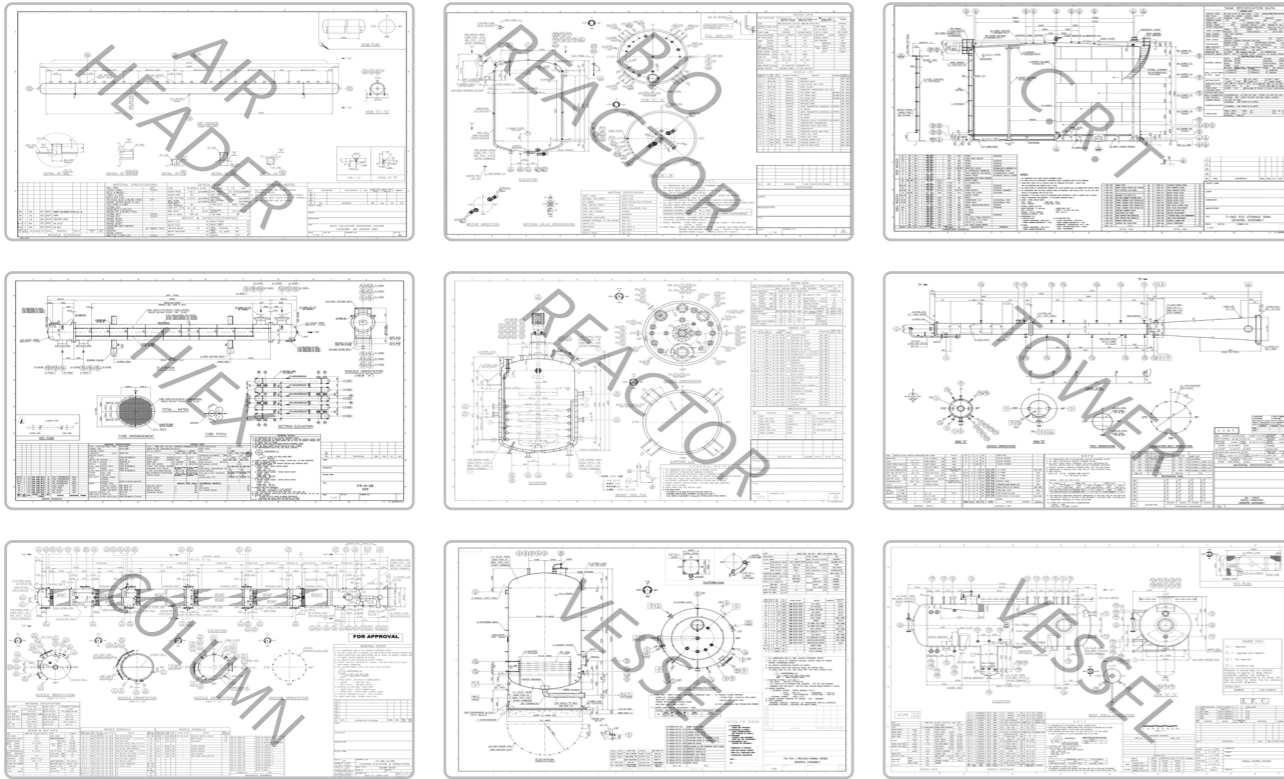

PLANT - PFD / P&ID / PIPING

일반적인 공장보다 규모가 작고 실험실 규모보다 큰 공장설비의 설계로서 공정설계부터 실시설계까지 모든 설계 진행 가능합니다.

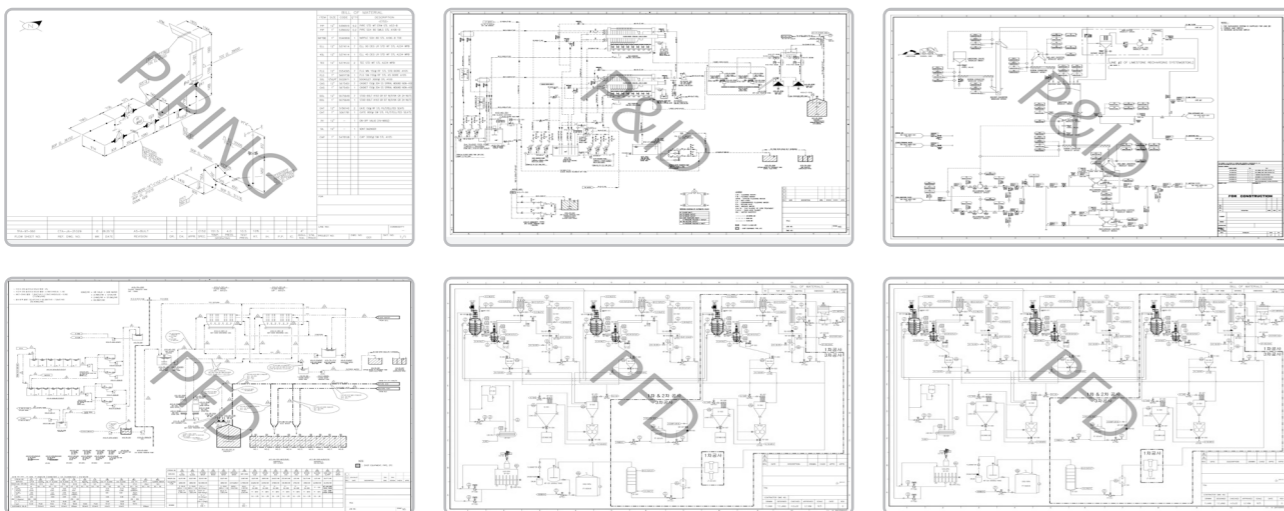

설계계산 Design Calculation

■ 설계코드
ASME SEC.VIII DIV.1,2 / KS B6750 / JIS B8265 /
산업통상자원부 고시 / KGS AC111 / ASME SEC. X / API
620,650 / 선급코드(KR, ABS, DNV.GL, LR, RINA) 등

■ 운용 프로그램
COMPRESS / MECAL / HTRI / MIDAS / ANSYS / 기타 자체프로그램
제작 및 적용



01 강도계산

ASME BPVC. SEC.VIII Division 1, 2 - 미국 기계학회 표준
KS B 6750 - 한국산업표준
JIS B 8265~7 - 일본 공업규격

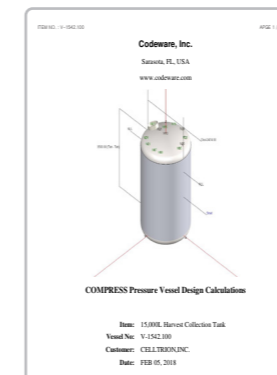

COMPRESS 프로그램

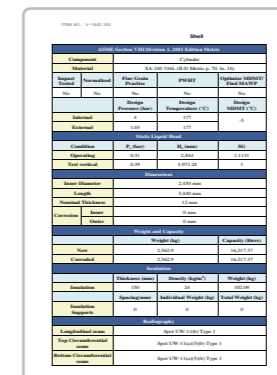

MECAL(한글) 프로그램

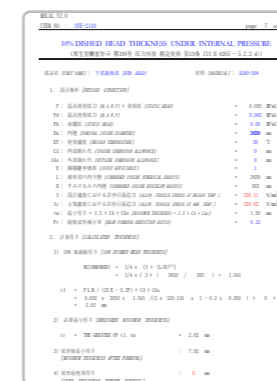

MECAL(영어+한글) 프로그램

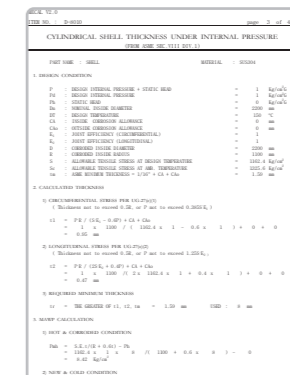

MECAL 프로그램

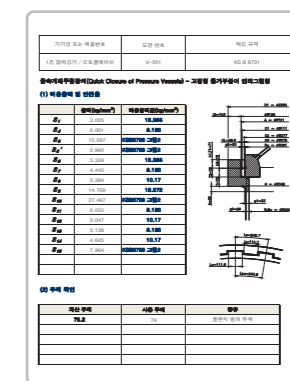

급속개폐장치 / 클램프 계산

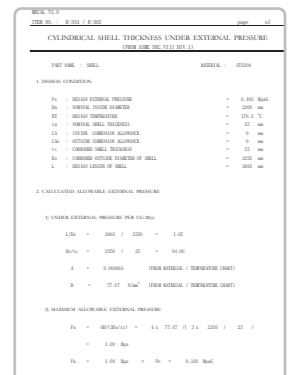

국내품 인증

Domestic Equipment Certification



01 국내 압력용기 검사기관

- 한국에너지공단(KEA)
- 한국산업안전보건공단(KOSHA)
- 한국가스안전공사(KGS)
- 한국전기안전공사(KESCO) (발전설비에 사용되는 압력용기만 취급)



02 주요 기관별 검사대상 기준

	한국에너지공단(KEA)	한국산업 안전보건공단(KOSHA)	한국가스안전공사(KGS)
검사 대상	압력X부피=0.004를 초과하고 열을 사용하여 가열, 증기발생, 비점초과(대기압초과)-1종 압력용기 최고사용압력(Mpa)이 0.2Mpa를 초과하는 기체(증기)를 보유하는 용기-2종 압력용기	화학공정 유체 취급용기 - 각종 압력용기 압력 외의 그 밖의 용기 (공기/질소 탱크) - 을중 압력용기 최고사용압력 0.2 MPa 초과	액화가스 - 0.2 MPa이상 압축가스 - 1 MPa이상
검사 코드	산업통상자원부 or KS B 6750 고시 ASME SEC.VIII Div.1	KS B 6750-3 ASME SEC.VIII Div.1	KGS AC111 ASME SEC.VIII Div.1
검사 순서	용접검사 > 구조검사 > 설치검사	서면심사 > 개별 제품심사 (재료, 용접, 내압)	설계검토 > 특정설비현장검사 (재료, FIT-UP, 용접, 내압)

03 검사품 인증 흐름



04 국내 각 기관별 인증서

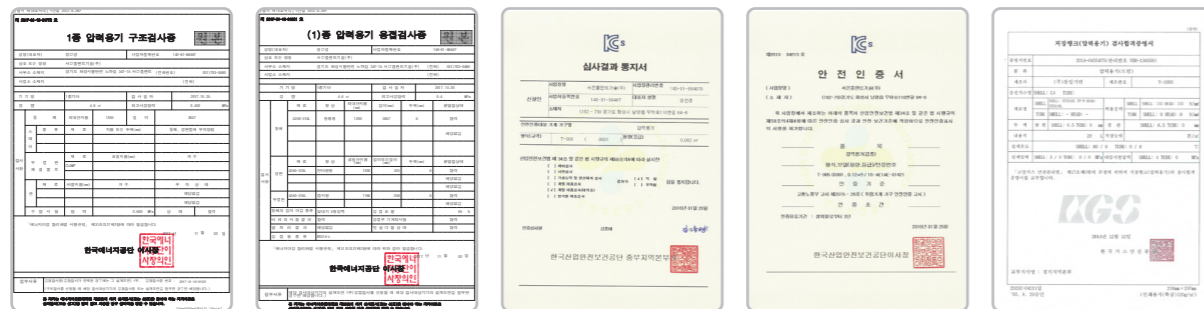

수입품 인증

Certification of Imported Equipment



01 해외 검사 인증 안내 (수입 압력용기)

해외의 압력용기를 국내로 수입하려는 경우, 그 압력용기에 대해 검사품 유무판단부터 인증서를 받기까지의 전과정을 모두 대행해 드리고 있습니다. (신청 / 서류 / 해외현장검사 / 통역 / 교육 / 국내설치 등)
보다 자세한 내용은 당사가 운영하는 블로그 <http://blog.naver.com/septech> 에서 자세하게 다루고 있습니다.

	한국에너지공단(KEA)	한국산업 안전보건공단(KOSHA)	한국가스안전공사(KGS)
검사 대상	서류심사 승인 후 해외제조 현장검사 실시	① 공단과 MOU체결된 국제공인기관에서 인증한 경우 검사면제 ② 국내 검사와 동일. 서면심사 승인 후 해외제조 현장검사	① 공단과 MOU체결된 국제공인기관에서 인증한 경우 검사면제 ② 해외제조 현장검사 + 국내 내압검사
검사 코드	산업통상자원부 or KS B 6750 고시 ASME SEC.VIII Div.1	KS B 6750-3 ASME SEC.VIII Div.1	KGS AC111 ASME SEC.VIII Div.1
검사 순서	다량의 동일한제품의 제조시 공장등록심사하여 검사완화 가능		특정설비제조허가증을 취득해야만 제조가능

02 검사품 인증 흐름



국내 입고 후 설치검사 또는 정기검사, 계속사용검사 지원

한국에너지공단 수입 검사 대행 (압력용기)



01 KEA 검사개요

‘에너지이용합리화법’ 개정으로 2017년 12월 3일 이후에 수입되는 검사대상기기에 대해 국내와 동일한 기준으로 제조업체 현장에서 제조검사를 수행하게 되었습니다.

KEA 수입용기 검사는 다른 나라의 검사와 많이 다른 특징들이 있습니다. 특히 사용 재질에 따라 적용되는 국내기준이 다릅니다. (아래 표 참조)

또한 해외 제조업체는 국내의 적용기준을 알지 못하므로 인증 및 제작과정에 있어 많은 어려움을 느끼고 있습니다. 이에 따라 서은플랜트기술(주)에서는 이런 어려움을 극복해 드리하고자 KEA검사와 관련된 모든 부분을 컨설팅 해 드립니다.



02 KEA 검사대상 및 종류

· 석유화학, 바이오, 제약, 식품, 에너지, 신소재 분야에서 열매체를 이용한 고온, 고압의 압력용기
[에너지이용합리화법 시행규칙 제31조의 6 참조]

· 검사기기 종류

- 압력용기(pressure vessel), 열교환기(heat exchanger), 반응기(reactor), 오토클레이브(autoclave), 살균기(sterilizer), 레토르트(retort), 교반기(agitator), 추출기(extractor), 증발기(evaporator), 염색기(dyeing machine), 바이오시밀러(biosimilar), 바이오리액터(bioreactor), 발효기(fermentor), 글라스라인드 용기(glass-lined vessel) 등

03 KEA 검사기준

구분	한국산업표준(KS)	산업통상자원부 고시(MOTIE)
기술기준	KS B 6750 (=ASME Sec.VIII div.1)	산업통상자원부 고시 제2024-184호
사용가능 재질	KS 또는 ASME 재질만 가능	KS 재질 또는 동등이상 재질 (JIS, EN, GB)
품질관리 체계	문서화된 시스템 요구	요구하지 않음 (단, WPS는 필요)
시편시험	특정한 요건에서만 요구	동체길이 또는 둘레이음 용접부에 대해서 요구
자체검사 인정	비파괴, 기계적 시험 등은 각국 정부에서 운영하거나 인정받은 업체	

04 KEA 수입용기 검사절차

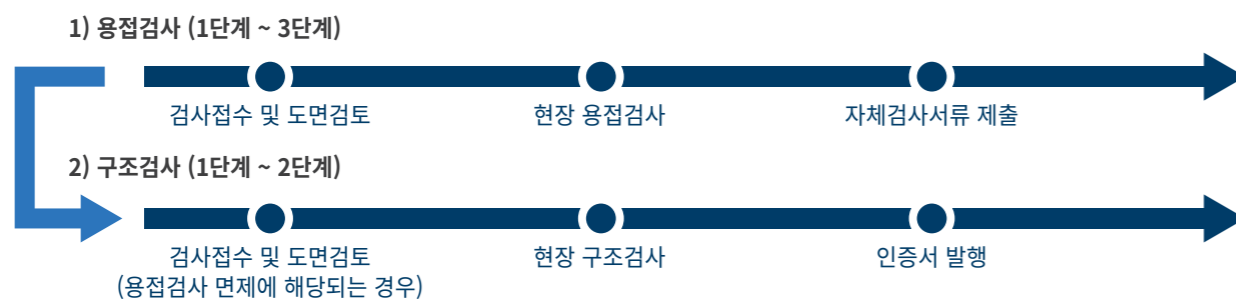

에너지공단, 산업안전보건공단, 가스안전공사 수입품 검사 인증대행

01 서은플랜트기술(주) 소개

서은플랜트기술(주)는 KEA, KOSHA, KGS 수입압력용기 인증 대행 업체입니다.

지난 40여년동안 엔지니어링 사업을 통해 축적된 노하우와 경험을 바탕으로 수입 기기의 서류, 도면, 검사, 설치에 관련된 모든 부분에 대한 컨설팅을 해드리고 있습니다.

02 서은플랜트기술(주)의 고객

수입 및 수출업체 : 프로젝트 발주처(사용자), 장비공급업체(무역업체), 제조자(해외업체)

03 서은플랜트기술(주)의 업무범위

- 1) 계약시 필요한 내용 안내
- 2) 제조프로세스에 맞춘 납기 일정 관리
- 3) KEA, KOSHA, KGS 검사관련 사전미팅 실시
- 4) KEA, KOSHA, KGS 요구사항에 따른 도면리뷰 및 다큐먼트 작성
- 5) 서류합격 시 까지 KEA, KOSHA, KGS와의 커뮤니케이션 전담
- 6) 용접검사와 구조검사 현장 출장 검사 동행
- 7) 국내이송 후 설치검사 합격까지 안내

04 서은플랜트기술(주)의 협업의 필요성

- 1) 당사에서는 40여년의 엔지니어링 경력을 바탕으로 전문성을 가지고 컨설팅을 해드리고 있습니다.
- 2) 당사에서는 서류, 도면, 검사부터 국내 납기, 설치완료까지의 모든 부분을 고객대신 직접 관리해 드립니다.
- 3) 당사에서는 제조 및 납기 일정에 맞춰 차질없이 진행해 드립니다.

예상소요시간 : 서류승인 - 약3주, 검사승인 - 약6주

05 서은플랜트기술(주)의 실적

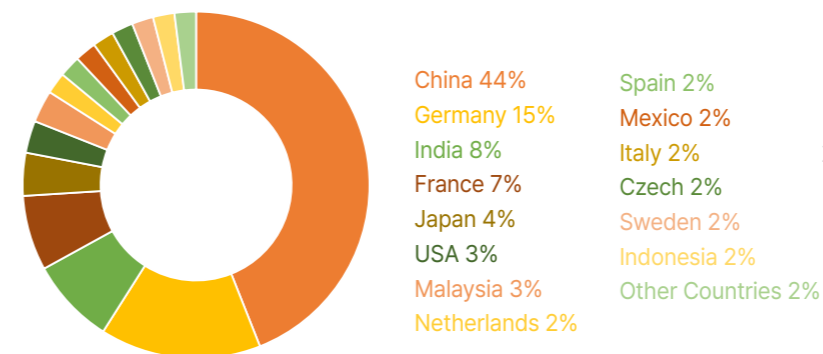

서은플랜트기술(주)에서는
2017년 12월 3일 수입용기검사 시작이후로
약 69개의 국가에서 2800여대 이상의
압력용기 검사인증 획득 및 진행 중

06 서은플랜트기술(주)의 기타 업무

- 국내인증 및 해외수입인증 - 한국에너지공단(KEA), 안전보건공단(KOSHA), 가스안전공사(KGS), 선급인증(DNVGL, LR, ABS)
- 기본&상세도면 / 강도계산 / 열계산 / FEA / 공정설계 / P&ID / 내진설계
- 파일럿플랜트(PILOT PLANT) / 테스트베드(TEST BED) / 연구목적(LAB BENCH SCALE)/ 배관(PIPING)



선급품 인증

Classification Equipment Certification



01 선급 검사기관

- KR(Korean Register of Shipping, 한국 선급)
- ABS(American Bureau of Shipping, 미국 선급)
- DNV.GL(Det Norske Veritas&Germanischer Lloyd, 노르웨이선급)
- LR(Lloyds Register, 영국 선급)
- NK(NIPPON KAIJI KYOKAI, 일본 선급)
- RINA(Registro Italiano Navale, 이탈리아 선급)



02 검사품 인증 흐름

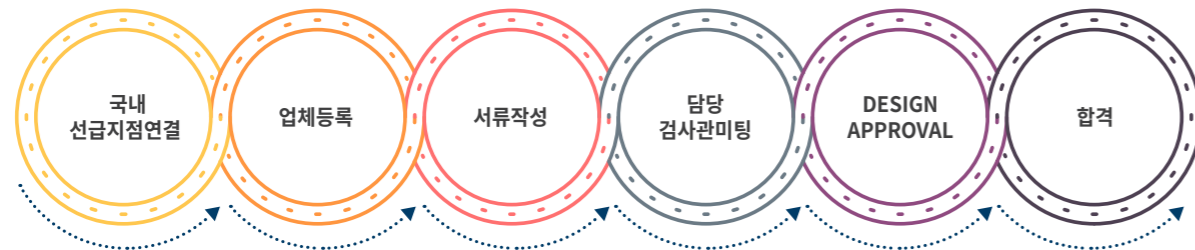

03 주요 선급 기관별 인증서 샘플

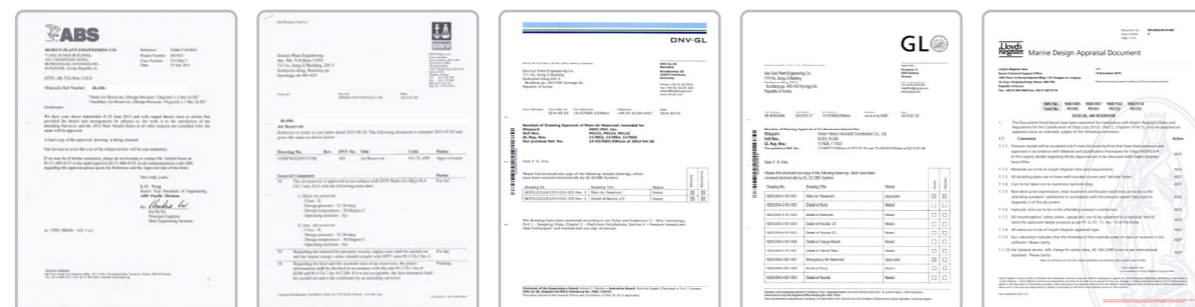

기타 검사 인증대행

Other Inspection & Certification Agency Services



01 한국에너지공단 (KEA)

- 설치검사** : 검사대상기기를 설치하여 사용하려는 자 [에너지이용합리화법 제39조]
- 개방검사** : 최초 설치검사 후 2년 주기로 검사를 받아 기기를 계속 사용하려는 자 [에너지이용합리화법 제31조]
- 계속사용검사** : 검사의 유효기간이 끝나는 검사대상기기를 계속 사용하려는 자 [에너지이용합리화법 제31조 제19항]
- 개조검사** : 검사대상기기를 개조하여 사용하려는 자 [에너지이용합리화법 제39조]
- 설치장소 변경검사** : 검사대상기기 설치장소를 변경하려는 자 [에너지이용합리화법 제39조]

02 한국산업안전보건공단 (KOSHA)

- 안전검사(정기검사)** : 안전검사대상기계에 해당하는 기계의 안전검사 실시 [산업안전보건법 제93조제1항]
- 자율안전확인신고** : 자율안전확인대상기계제품에 해당하는 기계는 확인신고 [산업안전보건법 제89조제1항]
- 유해위험방지계획서** : 제품의 생산 공정과 직접적인 기계, 건강장해를 방지하기 위하여 사용하는 기계, 건설공사착공하려는 경우 [산업안전보건법 제42조1항]
- 공정안전보고서(PSM)** : 사업장에 대통령령으로 정하는 유해하거나 위험한 설비가 있는 경우 [산업안전보건법 제44조1항]
- 화학사고 장외영향평가서** : 유해화학물질 취급시설을 설치, 운영하려는 자 [화학물질관리법 제23조]

03 한국가스안전공사 (KGS)

- 특정설비 제조허가증 취득지원** : 고압가스안전관리법 제5조제1항
- 해외업체 공장등록 지원**

04 기타 검사

- 방폭 인증** : IECEx / KC 등 전기에 해당하는 품목

컨설팅 Consulting



01 설계 교육

- ① ASME CODE - 설계 / 제작 교육
- ② KS CODE - 설계 / 제작 교육
- ③ JIS CODE - 설계 / 제작 교육
- ④ API650 CODE - 설계 / 제작 교육
- ⑤ 설계 프로그램 운용방법 교육 - COMPRESS / MECAL 등

02 국내 / 수입 검사 과정 교육

검사의 시작부터 인증, 유지보수까지 전 프로세스(설계 + 제작 + 검사준비) 교육 진행

- 국내 및 수입 압력용기의 경우 현장미팅 진행 가능합니다.
- 검사교육 대상자는 대부분 아래의 경우에 해당됩니다.
- 검사교육 대상자는
 - ① 국내 수입의 경우 - 해외 제조업체 담당자
 - ② 국내 검사품의 경우 - 제조업체 담당자
 - ③ 사용자 / 대리인 / 무역업자

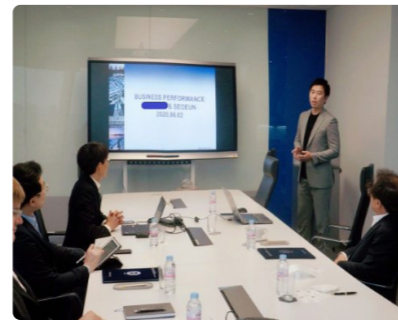

한국에너지공단 수입 검사의 경우 현장 입회검사를 반드시 하기 때문에 국내 코드에 따른 해외제조업체 관련자의 대응이 반드시 필요합니다.

03 법규검토 및 견적지원

- ① 압력용기 법규검토
 - 압력용기의 검사대상품 판단 / 면제대상품 / 1종,2종 구분 / 갑종,을종 구분
 - 법규 검토를 정확히 하여 추후 발생할 수 있는 문제를 사전에 해결하여 드립니다.
- ② 압력용기의 검사대상기기 우선순위
 - 검사기관별 우선순위는 아래와 같습니다. 본인의 압력용기가 상위 기관 검사품에 해당이 되면 아래 근거로 인해 반드시 상위기관에서 검사를 받아야 합니다.
 - (가스안전공사 > 한국에너지공단 > 한국산업안전보건공단)**
 - 근거 : 한국산업안전보건공단 - [산업안전보건법 시행규칙 제58조의 2]
 - 한국에너지공단 - [에너지이용 합리화법 시행규칙 제1조의 2]
- ③ 각종 승인서류 작성
 - 고객이 요구하는 각종 승인서류(JOB REQUIREMENT SPECIFICATIONS, WPS & PQR, INSPECTION & FABRICATION PROCEDURE, LOADING DATA 등)의 작성을 지원해 드립니다.
- ④ 견적 지원 업무
 - 설계 / 인증 / 컨설팅 등 당사에서 제공하는 업무에 대한 모든 견적을 제공해 드립니다.
- ⑤ 각종 승인서류의 검토 지원
 - VENDOR에서 제출되는 도면, 강도계산서, 검사서류 등의 각종 서류를 고객의 요구사항서 및 설계코드 / 법적기준에 따라 검토 가능합니다.

04 제작지원

테스트베드 Test bed



01 국내 유일한 테스트베드 설계 업체 - 생각을 현실로

테스트베드

기업이나 연구소, 대학교 에서 개발한 각종 신기술 및 시제품의 성능, 효과, 안정성, 양산 가능성, 편의성 등을 시험하기 위한 환경, 공간, 시스템, 설비(시설) 등을 마련하여 실제 테스트 가능하도록 설계 및 실현하는것을 의미합니다.

당사에서는 테스트베드의 설계에 대한 많은 경험을 가지고 있으며 고객의 생각을 실현 및 구현 가능하도록 아이디어를 제시해드릴 수 있습니다.

- 수입제품 국산화(Localization Development) 및 제품개발 수행 가능
- LAB SCALE BENCH / R&D 연구과제 / 정부과제 수행 가능

02 테스트베드 수행실적

- 사 업 명** 순환유동층 보일러 테스트베드
- 주요내용** 순환유동층 보일러 Furnace 음향방출 고장예측 진단시스템 개발
- 고 객 사** 한국에너지기술연구원

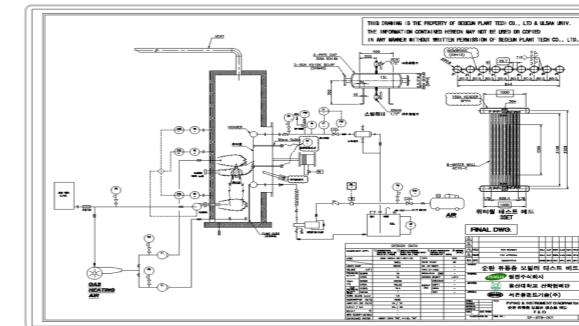

- 사 업 명** 원전 회전기 복합고장 알고리즘 및 데이터베이스 개발ENGINEERING
- 주요내용** Total piping system 음향방출 고장예측 진단시스템 개발
- 고 객 사** 한국서부발전(주)

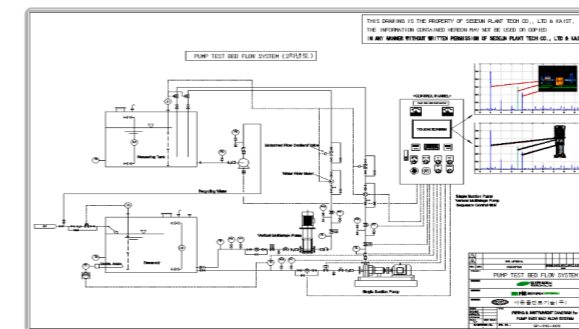

테스트베드 수행실적

사업명 자동차 폐촉매로부터 전기화학적 백금 침출 기술 검증을 위한 Basic Engineering 설계
주요내용 자동차 폐촉매로부터 전기화학적 백금 침출 기술 검증
고객사 한국지질자원연구원

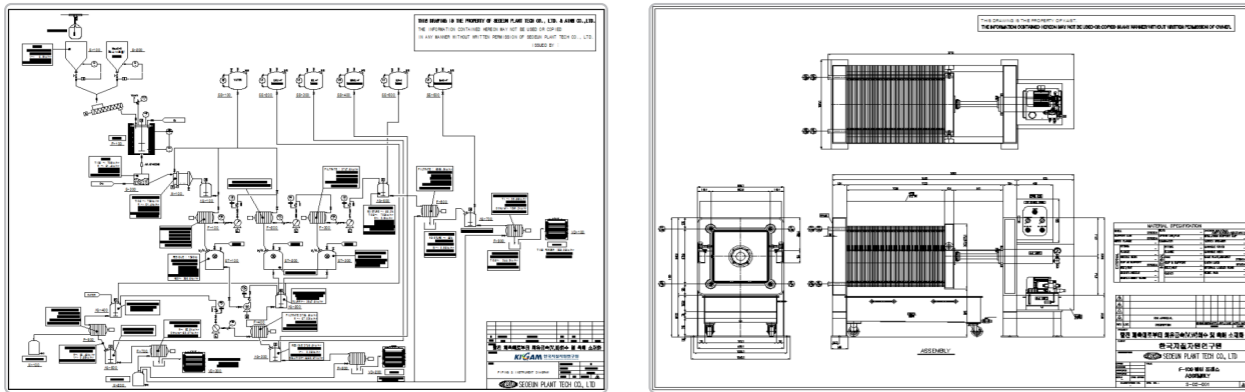

사업명 Gas Turbine Inlet Air 수분제거 Coalesce Filter 개발
주요내용 발전소의 지리적 특성 및 잦은 황사로 Air Intake System 내부에 수분과 먼지 누적이 심화 TEST.
고객사 한국서부발전(주)

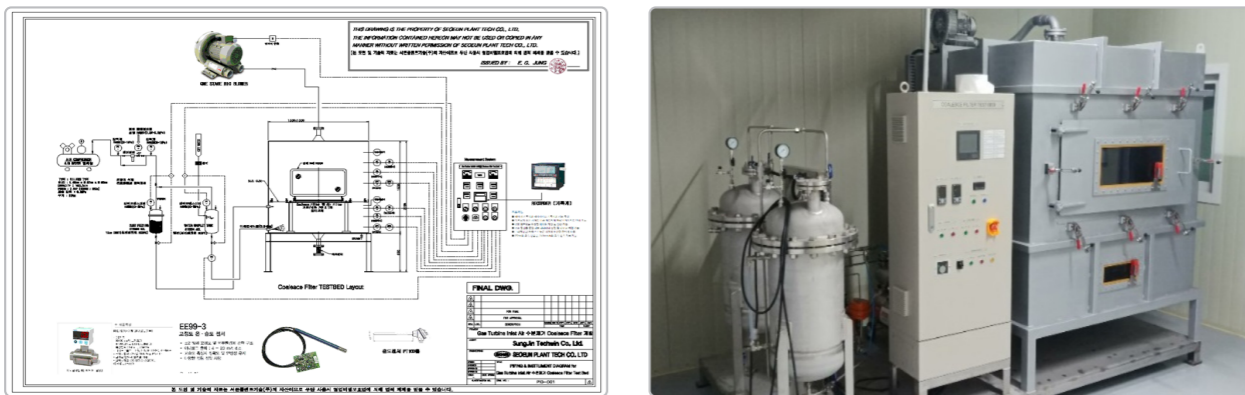

사업명 EGT 센서 신뢰성 시험 TESTBED 구축
주요내용 Gas Turbine의 Frame에 부착되어 연소된 Gas의 온도를 감지, Turbine의 연소상태를 실시간 모니터링하여 Gas Turbine을 효율적이고 안전하게 제어하기 위해 사용되는 온도센서 개발
고객사 한국서부발전(주)

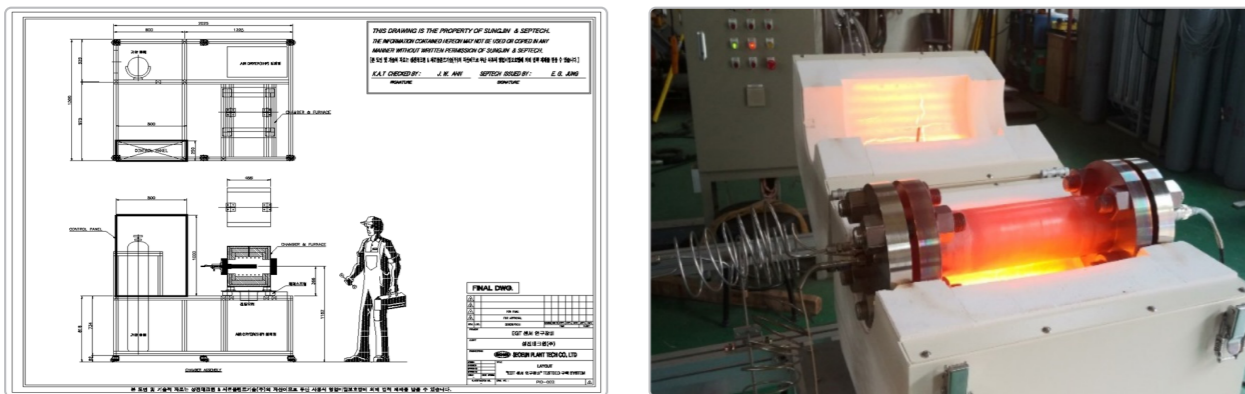

스페셜 제작 프로젝트
 Special Manufacture Project



01 세계 최고의 기술로 특별 아이템 제작

Special Manufacture Project
 고난도 고사양의 장치류(압력용기, 열교환기, 타워 등)를 제작하고, 석유화학·고순도GAS, 정밀화학, 바이오, PLANT 등의 공정설계, P&ID 등의 설계 및 제조를 완벽히 수행함은 물론, 연구용 BATCH SYSTEM이나 PILOT PLANT, COMMERCIAL PLANT 등을 수행할 수 있는 능력을 갖추고 있습니다.

02 Special Manufacture Project 수행실적

사업명 SiCL4 정제 STATION SYSTEM
주요내용 원료 SiCL에 함유된 금속불순물, 기체불순물, 수분 및 유분 등을 정제하여 고순도의 SiCL4를 제조하는 SiCL4 정제방법에 관한 것으로 증류공정을 이용하여 SiCL4 불순혼합가스를 동시 또는 연속적으로 제거하여 99.999995% 이상의 고순도 SiCL4 정제 PLANT
고객사 솔머티리얼즈(주)



사업명 중질타르 판매설비
주요내용 현대제철 연간 제강생산공정에서 부산물로 발생되어 나오는 중질타르를 별도의 판매 목적으로 COMMERCIAL PLANT 설치
고객사 현대제철(주)



기업 주요실적

Project References



01 산.학.연.관 프로젝트 주요 관계사



해외

미국(ALBEMARLE CORP, ROSS EQUIP. , LOST WAX, KNBS, MATHESON GAS , KBR, ENDORFF 등)
 중국(WUXI BIOLOGICS, ANHUI JINMA, DTS, JIBO TAIJI, TECH SOLUTION, INTERCONSTEK, SUNGIL HITEK 등)
 일본(HITACHI, TOYO ENG'G, CHISSO ENG'G, BASF, KOBELCO, TOYOBO, YAMAGEN, KAJIWARA, HOSOKAWA 등)
 프랑스(STERIFLOW, 3C FRANCE, PETRON BATAAN REFINERY등), 인도 BIOZEEN,
 독일(BOSCH, DFT, JANSSEN, THEMATEK, INTRON 등), 사우디아라비아 SIPCHEM, S.O.C,
 카타르 TASSNI, 오만(OMAN OIL COMPANY E&P LLC, SALALAH METHANOL 등), 벨기에 SOLVAY,이탈리아 VELIA

산(産) - 산업분야

삼성(중공업, 엔지니어링, 바이오에피스,바이오로직스, 전자) 포스코(홀딩스, 퓨처엠, 엠텍), LG(디스플레이, 화학, 에너지솔루션, 전자)
 SK(바이오팜, 바이오사이언스, 이노베이션, 케미컬), KAI, 한화(TECH, 케미컬), HJ중공업, 두산, 한국타이어, 대림산업, 후성, 한솔케미컬, 휴비스
 덕산, OCI, 다루케미컬, 금호 P&B케미컬, 한일시멘트, 남해화학, 한미약품, 켐트로스, 셀트리온, 덕산유엠티, 한솔케미컬,
 휴켄스, GS바이오, GS칼텍스, KCC실리콘투, LG전자, 한솔제지, 녹십자, 한국유나이티드제약, 성신양회, 삼표시멘트, 금호미쓰이화학

학(學) - 교육시설

KAIST, 아주대학교, 부산대학교, 서울대학교, 울산대학교, 전북대학교, 충남대학교 외 30여개 대학

연(研) - 연구설비

한국항공우주연구원, 한국지질자원연구소, 국방과학연구소(엔진시험 설비), 한국기계연구원, 에너지기술연구원, 에너지기술평가원,
 국립환경과학원, 충북내수면연구소, 한국화학연구원, 한국원자력연구원, 한국핵융합연구원, 한국전력기술 외 20개 연구단체

관(官) - 정부 및 군(軍)관련 기관

국방부, 한국광해광업공단, 코레일, KT, 창원시, 대구시, 부산시, 서울시 등 각 지방자치시도
 HOII, 한국남동발전, 한국서부발전, 한국동서발전, 한국수력원자력 외 50개 공공기관 및 지자체

NAME OF PROJECT	DESCRIPTION	CLIENT	SITE	YEAR
BCC PROJECT	VESSEL	SSANGYONG OIL REFINERY	KOREA	1998
INCINERATOR SYSTEM	INCINERATOR	HANYANG CHEMICAL	KOREA	1998
E/O PURIFICATION PROJECT	TOWER	HYUNDAI PETROCHEMICAL	KOREA	1998
BTX PROJECT	VESSEL / H/EX.	JEONGWOO CHEMICAL	KOREA	1998
NCC PROJECT	H/EX.	NAMHAE CHEMICAL	KOREA	1998
JILIN CAK PROJECT	FLARE STACK	TOYO ENGINEERING	JAPAN	1998
COMPANY PARK BUILDING	TOTAL ENGINEERING	KYUNGHANG NEWSPAPER	KOREA	1998
TCL PROJECT	VESSEL / TOWER	TOYO ENGINEERING	JAPAN	1998
HSR PROJECT	VESSEL / REACTOR	HYUNDAI PETROCHEMICAL	KOREA	1998
FCC PROJECT	VESSEL(HIGH PRESSURE)	YUKONG	KOREA	1998
CUPOLA FLUJE CLEANING SYSTEM	FILTER / H/EX. / DUCT STEEL S TRUCTURE / PIPING	BUEKSAN	KOREA	1998
RFCC F/G SOX SCRUBBER	STRUCTURE	SK CORPORATION	KOREA	1998
BIBA-1 PROJECT	VESSEL	BIBACO	KOREA	1998
SOLVENT RECOVERY SYSTEM	VESSEL	YOUL CHON CHEMICAL	KOREA	1998
OZONE TANK SYSTEM TANK & PIPING	TANK, PIPING	YOUL CHON CHEMICAL	KOREA	1998
SBR-9 PROJECT	C.R.T	KUMHO PETROCHEMICAL	KOREA	1999
TSING MA BRIDGE PROJECT	TOTAL	HONGKONG	HONGKONG	1999
UTILITY & FACILITY PROJECT	TOWER	DAELIM INDUSTRIAL	KOREA	1999
PTA PROJECT	VESSEL	SAMSUNG GENERAL CHEMICAL	KOREA	1999
LG 3AA PROJECT	C.R.T	LG ENGINEERING	KOREA	1999
PL/TCM PLANT PROJECT	TOTAL	HANBO IRON STEEL	KOREA	1999
FEB PROJECT	TOTAL	DONGYANG NYLON	KOREA	1999
YER-11 PROJECT	H/EX.	KUMHO PETROCHEMICAL	KOREA	1999
OXYGEN SUPPLY PLANT PROJECT	TOTAL	POSCO	KOREA	1999
SR PROJECT	C.R.T	LG ENGINEERING	KOREA	1999
HP24M PROJECT	VESSEL	OCI	KOREA	1999
CRT PROJECT	H/EX.	KOOKDO CHEMICAL	KOREA	1999
P PROJECT	TOWER / H/EX.	DCI / KT	KOREA	1999
40,000 MTY K-RESIN PROJECT	FILTER, H/EX.	DAELIM INDUSTRIAL	KOREA	1999
396,000 T/Y #3 SULFURIC ACID PLANT	BIG TOWER	NAMHAE CHEMICAL	KOREA	1999
FLARE STACK	TOTAL	LG CHEMICAL	KOREA	2000

NAME OF PROJECT	DESCRIPTION	CLIENT	SITE	YEAR
YDR-4 PROJECT	REACTOR / TOWER / H/EX.	KKPC	CHINA	2000
VCM PROJECT	TOWER / H/EX.	HYUNDAI PETROCHEMICAL	KOREA	2000
PEB STRUCTURE	TOTAL	HANKOOK TIRE	KOREA	2000
KEROSENE/ DIESEL PROJECT	STRUCTURE / H/EX.	LG CALTEX OIL	KOREA	2000
NO.2 UTILITY OFF-SITE PROJECT	VESSEL / C.R.T	SAMSUNG GENERAL CHEMICAL	KOREA	2000
CDP-1 PROJECT	TOTAL	SK NJC	KOREA	2000
NO.2 PP PROJECT	VESSEL / H/EX.	PEMEX	KOREA	2000
HEAVY NAPHTHA SPLITTER UNIT	TOTAL	SAMSUNG GENERAL CHEMICAL	KOREA	2000
P PROJECT	TOWER / H/EX.	KT	KOREA	2000
AGC AVL PROJECT	VESSEL / H/EX.	CHISSO ENGINEERING	JAPAN	2000
GWANGJU 2ND FACTORY	TOTAL	SAMSUNG ELECTRONICS	KOREA	2000
HYDROGEN PLANT	VESSEL	FPC	KOREA	2000
FLARE STACK SYSTEM	FLARE STACK	PE CHEMICAL	TAIPEI	2001
CHEONGJU NO.5 PLANT	VESSEL	DAESUNG SANSO	KOREA	2001
PET OFF GAS SCRUBBING SYSTEM	TOWER	SAMNAM	KOREA	2001
AGC AVL PROJECT	VESSEL / H/EX.	CHISSO ENGINEERING	KOREA	2001
NEW TDI PROJECT	VESSEL / H/EX.	BASF	JAPAN	2001
NEW HYVAHL COMPLEX PROJECT	H/EX.	S-OIL	KOREA	2001
VOC SYSTEM	VESSEL	BASF	KOREA	2001
YM-2 PROJECT	H/EX.	LG	KOREA	2001
KA1, K2, K4 PROJECT	VESSEL / H/EX.	CHEIL ENGINEERING	KOREA	2001
SGC AROMATICS REVAMPING	H/EX.	SAMSUNG ENGINEERING	KOREA	2001
TORAY OCP-3 PROJECT	VESSEL H/EX.	TEK KOREA	KOREA	2001
EXPANSION PROJECT 2002	VESSEL / H/EX.	LG NIKKO COPPER	KOREA	2002
NYLON POWDER 50 MTPY PLANT	VESSEL / H/EX.	SHINHO PETROCHEMICAL	KOREA	2002
WORK TANK FABRICATION	VESSEL	DAEWOO ELEC.	KOREA	2002
VITAMIN PRODUCTION PROJECT	VESSEL / H/EX./ C.R.T	BASF	KOREA	2002
GWANGMYEONG DISTRICT HEATING	HEATER(TWO ZONE)	LG POWER	KOREA	2002
HP-SCWO PILOT PROJECT	VESSEL	KOREA PETROCHEMICAL.	KOREA	2002
PL/TCM PROJECT	H/EX.	DONGBU STEEL	KOREA	2002
BAIONGAN BLUE SKY PROJECT	VESSEL	HITACHI	KOREA	2002

NAME OF PROJECT	DESCRIPTION	CLIENT	SITE	YEAR
S-PROJECT	VESSEL / H/EX.	KCC	KOREA	2002
WATER JET PROJECT	SPECIAL SYSTEM	MINISTRY OF NATIONAL DEFENSE (국방부)	KOREA	2002
FPCC ARDS-1 I PROJECT	VESSEL	FORMOSA	TAIWAN	2003
SK 2nd LBO PROJECT	TOTAL	SK CHEMICAL	KOREA	2003
CHANGWON CITY HALL	TOTAL	GOVERNMENT	KOREA	2003
AIR FIN COOLER	COOLER	HYUNDAI OIL	KOREA	2003
BP SHAH DENIZ PROJECT	VESSEL	SOC	SAUDI ARABIA	2003
SK 2nd LBO PROJECT	TOTAL	SK CHEMICAL	KOREA	2004
CHANGWON CITY HALL	TOTAL	GOVERNMENT	KOREA	2004
HANWHA VENT CONDENSER	H/EX.	HANWHA	KOREA	2004
DONGBU H/EX.	H/EX.	DONGBU	KOREA	2004
KANGMYUNG LOCAL HEATING	H/EX.(TWO ZONE)	LG CONS.	KOREA	2004
AN WASTE WATER T-N TREATMENT SYSTEM	TOTAL	TAEKWANG PETRO.	KOREA	2004
J-PROJECT	REACTOR / STORAGE TANK	JOHN ZINK	THAILAND	2004
5th GAS SEPARATION PLANT PROJECT	VESSEL	HITACHI	JAPAN	2004
M-PROJECT	REACTOR	HANMAEK IND.	MYANMAR	2004
FLARE STACK	FLARE STACK	HAMWORTHY	INDONESIA	2004
SUCTION HEATER OF FUEL OIL	STORAGE TANK	KOREA WESTERN POWER (한국서부발전)	KOREA	2004
CURING OVEN INCINERATOR	H/EX.	BUEKSAN	KOREA	2004
N-PROJECT	REACTOR / VESSEL	HYOSUNG CORP.	KOREA	2004
LOTTE SAMGANG CHON-AN FACTORY	VESSEL	DOOSAN MECHATEC	KOREA	2004
VENT CONDENSOR & H/EX.	H/EX.	DONG YANG CHEMICAL	KOREA	2004
SK COPORATION	STRUCTURE	DOOSAN MECHATEC	KOREA	2005
SOLVENT RECOVERY SYSTEM	TOTAL	SAMKUN E&C	KOREA	2005
OZONE TANK	PIPING / STRUCTURE	YOUL CHON CHEMICAL	KOREA	2005
YM-2 PROJECT	H/EX.	LG	KOREA	2005
KA1, K2, K4 PROJECT	TOTAL	CHEIL ENGINEERING	KOREA	2005
EXPANSION PROJECT 2002	VESSEL / H/EX.	LG NIKKO COPPER	KOREA	2005
WORK TANK FABRICATION	TOWER / VESSEL	DAEWOO ELEC.	KOREA	2005
VITAMIN B2 PRODUCTION PROJECT	VESSEL / C.R.T / H/EX.	BASF	KOREA	2005
GWANGMYEONG DISTRICT	H/EX.(TWO ZONE)	LG POWER	KOREA	2005

NAME OF PROJECT	DESCRIPTION	CLIENT	SITE	YEAR
DONGBU H/EX.	H/EX.	DONGBU	KOREA	2005
AN WASTE WATER T-N TREATMENT SYSTEM	TOTAL	TAEKWANG PETRO.	KOREA	2005
FLARE STACK	FLARE STACK	JOHN ZINK	THAILAND	2005
5th GAS SEPARATION PLANT PROJECT	VESSEL	HITACHI	JAPAN	2005
M-PROJECT	REACTOR	HANMAEK IND.	MYANMAR	2005
FLARE STACK	FLARE STACK	HAMWORTHY	INDONESIA	2005
SUCTION HEATER OF FUEL OIL	STORAGE TANK	KOREA WESTERN POWER (한국서부발전)	KOREA	2005
N-PROJECT	REACTOR / VESSEL	HYOSUNG CORP.	KOREA	2005
N-PROJECT	ENG'G DWG.	HYOSUNG	KOREA	2006
PLASMA PILOT PLANT	VESSEL	KGC	KOREA	2006
PIT VESSEL	TOTAL	SEC	KOREA	2006
POHANG H2 PROJECT	VESSEL	BOCK	KOREA	2006
PILOT PLANT	H/EX.	JEIO	KOREA	2006
WTP 1st LINE TRANSFER PROJECT	PIPING / STRUCTURE / TOTAL EQUIPMENT	KAI	KOREA	2006
FORMOSA NINGBO	FILTER	FORMOSA	TAIWAN	2006
JEBEL ALI POWER PHASE 2	FILTER	HEC	KOREA	2006
INITIAL Z	VESSEL / H/EX.	SAN NOPCO	KOREA	2006
BD PROJECT	VESSEL / C.R.T	DANSUK	KOREA	2006
DUNG QUAT REFINERY PROJECT	STORAGE TANK	PETROVIETNAM	VIETNAM	2006
P2-PROJECT	VESSEL	SAMSUNG TOTAL PETROCHEMICALS	KOREA	2006
A-PROJECT	VESSEL / H/EX.	SK CHEMICAL	KOREA	2006
MODACRYL RESIN 800L PILOT PLANT	VESSEL	HANWHA CHEMICAL	KOREA	2006
SKICO REVAMP PROJECT	H/EX.	SK INCHEON OIL	KOREA	2006
CELLTRION EXPANSION PROJECT	VESSEL	CELLTRION	KOREA	2006
WTP 2nd LINE TRANSFER PROJECT	PIPING / STRUCTURE / TOTAL EQUIPMENT	KAI	KOREA	2006
HP-ECH PILOT	VESSEL / H/EX.	HANWHA CHEMICAL	KOREA	2006
P2 PROJECT	ENG'G DWG. TOTAL EQUIPMENT	OCI	KOREA	2007
HP-ECH PILOT	TOWER / VESSEL	HANWHA CHEMICAL	KOREA	2007
45m3 REACTOR	REACTOR	KOBELCO	JAPAN	2007
KPPR-PROJECT	REACTOR / VESSEL	KUMHO P&B CHEMICAL	KOREA	2007
P PILOT PROJECT	SPECIAL REACTOR	KCC	KOREA	2007

NAME OF PROJECT	DESCRIPTION	CLIENT	SITE	YEAR
DISTILLATION UNIT SYSTEM	TOTAL EQUIPMENT	KAYA ENERGY	KOREA	2007
B-1 PROJECT	TOWER / VESSEL / H/EX.	BIZEL CORPORATION	KOREA	2007
ACP PLANT PROJECT	VESSEL / C.R.T	ECOPRO	KOREA	2007
BPA(III) PLANT PROJECT	VESSEL	KUMHO P&B CHEMICAL	KOREA	2007
MIBK PLANT REVAMP PROJECT	TOWER	KUMHO P&B CHEMICAL	KOREA	2007
FUMED SILICA PROJECT	TOWER	KCC	KOREA	2007
KFCT PROJECT	C.R.T	OCI	KOREA	2007
GLOW 115MW CFB3 PROJECT	SPECIAL VESSEL	GLOW ENERGY PUBLIC	KOREA	2007
ARQ PROJECT	ENG'G DWG. TOTAL EQUIPMENT	TASSNI	QATAR	2008
HMC PP PROJECT LINE-3	VESSEL	HMC POLYMERS	KOREA	2008
40m3 REACTOR	SPECIAL REACTOR	KOBELCO	JAPAN	2008
RUSSIA PROJECT	REACTOR	SAMHWA MIXING TECH	RUSSIA	2008
THAILAND ASR PROJECT	REACTOR / VESSEL / H / EX.	HANWHA CHEMICAL THAILAND	THAILAND	2008
P2 PROJECT	TOWER / VESSEL / H/EX.	OCI	KOREA	2008
SALALAH METHANOL PROJECT	H/EX.	SALALAH METHANOL	OMAN	2008
P3 PROJECT	ENG'G DWG.	OCI	KOREA	2008
CNP PROJECT	TOWER / VESSEL / C.R.T	HANWHA TECH	CHINA	2008
CNP PROJECT	VESSEL	HANWHA CHEMICAL	CHINA	2009
P3.5 PROJECT	VESSEL	OCI	KOREA	2009
OSAN STEAM SUPPLY GENERATION	H/EX. (TWO ZONE)	KOSEP	KOREA	2009
DINH VU POLYESTER PLANT PROJECT	VESSEL	PV-TEX	VIETNAM	2009
HP-2 PROJECT	TOWER / REACTOR	HANSOL CHEMICAL	KOREA	2009
NO.4 DNT PROJECT	VESSEL / H/EX.	HUCHEMS	KOREA	2009
ADD ENGINE TEST FACILITY PROJECT	TOTAL	AGENCY FOR DEFENSE DEVELOPMENT	KOREA	2009
PAPER WASTE INCINERATION	INCINERATOR	HYOSUNG EBARA ENGINEERING	INDONESIA	2009
YEO SU THERMAL POWER PLANT UNIT 2	SILO	KOSEP	KOREA	2009
MAIN, AUXILIARY FUEL HEATER	TOTAL	AGENCY FOR DEFENSE DEVELOPMENT	KOREA	2010
GYPSUM WATER 2ND SLUDGE PROCESS	TOTAL	NAMHAE CHEMICAL	KOREA	2010
OCIMC PROJECT	ENG'G DWG.	OCI	KOREA	2010
P3.7 PROJECT	TOTAL EQUIPMENT	OCI	KOREA	2010
EA PROJECT	TOTAL EQUIPMENT	SIPCHEM	SAUDI ARABIA	2010

NAME OF PROJECT	DESCRIPTION	CLIENT	SITE	YEAR
NEOTECHS ROTARY PRESSURE FILTER	TOTAL	SK PETROCHEMICAL	KOREA	2010
CAPE PROJECT	C.R.T	KPX LIFE SCIENCE	KOREA	2010
CA2 PROJECT	VESSEL	OCI	KOREA	2010
AUTO CRAVE PROJECT	VESSEL	ROULUNDS RUBBER	DENMARK	2010
2x60MW MERAK CFPP PROJECT	SILO	PT. MERAK ENERGI INDONESIA	INDONESIA	2010
NO.4 DNT PROJECT	ENG'G DWG.	HUCHEMS	KOREA	2010
P4-PROJECT (18000 TON)	TOTAL	OCI	KOREA	2011
EAGLE PROJECT	REACTOR / VESSEL / H / EX.	HANWHA CHEMICAL	KOREA	2011
C.R.T (2000 M3)	C.R.T	SKC	KOREA	2011
SPC ULSAN NO.1 PTA DBN PROJECT	TOTAL	SAMSUNG TOTAL	KOREA	2011
NORTH STAR PROJECT (1200 M3)	D.R.T	THE DOW CHEMICAL COMPANY	KOREA	2011
A/R PILOT PROJECT	TOTAL	JEONBUK UNIVERSITY	KOREA	2011
NO.1 TAC PROJECT	H/EX.	SK INNOVATION	KOREA	2011
1000 MT/y K-991 3RD PLANT	TOWER / VESSEL / H/EX.	FOOSUNG CO., LTD.	KOREA	2011
GARNET BLASTING MACHINE	VESSEL	SAMSUNG HEAVY INDUSTRY	KOREA	2011
KPA(III) REVAMP PROJECT	TOWER	KUMHO P&B CHEMICAL	KOREA	2011
EDISON PROJECT	REACTOR	SAMSUNG BIOLOGICS	KOREA	2011
SMVR-01 PROJECT	TOTAL	SK PETROCHEMICAL	KOREA	2011
#2 BTX-PROJECT	VESSEL	HC PETROCHEM	KOREA	2011
NaOH CONCENTRATION	TOTAL	PKC CHEMICAL & BIOTECH	KOREA	2011
EA PROJECT	ENG'G DWG.	SIPCHEM	SOUDI	2011
CIVP PROJECT	REACTOR	HITACH PLANT TECHNOLOGIES	JAPAN	2011
3PZ-PROJECT	REACTOR	HONAM MITSUI CHEMICALS INC	KOREA	2011
EVALUATION REACTOR	PILOT PLANT SYSTEM	HANWHA	KOREA	2011
SOUTH PARS GAS FIELDDEVELOPMENT	PIPING	NIOC PARS OIL AND GAS CO.,LTD.	IRAN	2011
#2 BTX PROJECT	STRAINER	HC PETROCHEM	KOREA	2012
YDR-S-1 SSBR PROJECT	H/EX.	DAELIM INDUSTRIAL CO.,LTD.	KOREA	2012
NO.2 SPENT CAUSTIC INCINERATOR SYSTEM	INCINERATOR / VESSEL / H/EX / STACK	GS CALTEX CORPORATION	KOREA	2012
30,000 MTPA AC/ ECH PLANT	TOWER / VESSEL	SAMSUNG FINE CHEMICALS CO.,LTD.	KOREA	2012
REACTOR PROJECT	REACTOR	TOYOBO CO., LTD.	JAPAN	2012
MUSANDAM GAS PLANT	VESSEL / FILTER	OMAN OIL COMPANY	OMAN	2012

NAME OF PROJECT	DESCRIPTION	CLIENT	SITE	YEAR
DONGHAE BIOMASS POWER PLANT	SILO	KOREA EAST-WEST POWER	KOREA	2012
REFINERY MASTER PLAN 2 PROJECT	VESSEL	PETRON BATAAN REFINERY	FRANCE	2012
P3.9 PROJECT	VESSEL	OCI	KOREA	2012
PURE GROWTH PROJECT	ENG'G DWG.	ALBEMARLE CORPORATION	U.S.A	2012
CF DRYER PROJECT	VESSEL	YOUGUANG CHEMICAL CO.,LTD.	KOREA	2012
HIB 1000L PROJECT	VESSEL	LG LIFE SCIENCES CO.,LTD.	KOREA	2012
TOTE TANK PROJECT	VESSEL	BOKWANG CO.,LTD.	KOREA	2012
EDISON II PROJECT	REACTOR / VESSEL	SAMSUNG BIOLOGICS	KOREA	2013
LP-1 PPB EXTENSION PROJECT	REACTOR / VESSEL	HANWHA CHEMICAL	KOREA	2013
TRIM HEATER PROJECT	H/EX.	DAELIM INDUSTRIAL CO.,LTD.	KOREA	2013
P0093&P0095 PROJECT (ABS & G.L)	AIR RESERVOIR	HANJIN HEAVY IND.&CON.	PHIL- SUBIC	2013
OLE-SIV BENCH SCALE PROJECT	REACTOR / VESSEL	SK INNOVATION	KOREA	2013
RESIN REACTOR SYSTEMPROJECT	REACTOR / VESSEL / H/EX.	FTC KOREA CO.,LTD.	KOREA	2013
HYDROMETALLURGY PILOT PLANT	ENG'G DWG.	KORES	KOREA	2013
400 BAR TEST BENCH PROJECT	VESSEL (HIGH PRESSURE)	SVC	KOREA	2013
SEWAGE TREATMENT EQUIPMENT	VESSEL / H/EX.	BUSAN PORT AUTHORITY	KOREA	2013
AUTO CLAVE PROJECT	AUTO CLAVE	Hosiden Vietnam (Bac Giang) Co.,Ltd.	VIETNAM	2013
NCP0104-0119 PROJECT (DNV)	AIR RESERVOIR	HANJIN HEAVY IND.&CON.	PHIL- SUBIC	2013
CFRTPC PROJECT	REACTOR / VESSEL	HANWAH L&C	KOREA	2013
DEG DRYING FACILITY PROJECT	TOTAL	YOUKWANG CHEMICAL CO.,LTD.	KOREA	2013
WARA PRESSURE MAINTENANCE	STRUCTURE	KUWAIT OIL COMPANY (K.S.C.)	KUWAIT	2013
GMP PROJECT	REACTOR / VESSEL / H/EX.	NATURALENDO TECH CO.,LTD.	KOREA	2013
S721s PROJECT (DNV)	AIR RESERVOIR	HYUNDAI SAMHO	KOREA	2013
SLUDGE RECOVER PROJECT	STORAGE TANK / RECTOR	NAMHAE CHEMICAL CO.,LTD.	KOREA	2013
VACUUM DEFOAMER PROJECT	REACTOR / VESSEL	KISCO	KOREA	2013
NCP0123s PROJECT (G.L & RINA)	AIR RESERVOIR	HANJIN HEAVY IND.&CON.	PHIL- SUBIC	2013
DUST COLLECTOR PROJECT	VESSEL	KORAIL	KOREA	2014
RESIN PROJECT	VESSEL	SAMSUNG TOTAL	KOREA	2014
SLP CCGT Power Plant PROJECT	VESSEL / FRP VESSEL	SAMSUNG ENGINEERING	KOREA	2014
NCP0113 PROJECT	AIR RESERVOIR	HANJIN HEAVY IND.	PHIL- SUBIC	2014
WATER HEATING SYSTEM PROJECT	REACTOR / H/EX.	HANSEO CHEMICAL	KOREA	2014

NAME OF PROJECT	DESCRIPTION	CLIENT	SITE	YEAR
YANBU POWER AND DESALINATION PLANT	SILO / STRUCTURE	SALINE WATER CONVERSION CORP.	SAUDI	2014
NTP0137s PROJECT (DNV)	AIR RESERVOIR	HANJIN HEAVY IND.	PHIL-SUBIC	2014
Premixing PROJECT	VESSEL	OCI Special CO.,LTD.	KOREA	2014
PURIFICATION COLUMN PROJECT	TOWER / REACTOR	SOULBRAIN Co.,Ltd.	KOREA	2014
BCCM PLANT PROJECT	VESSEL	SEAH BESTEEL	KOREA	2014
FIXED BED REACTOR SYSTEM	VESSEL (HIGH PRESSURE)	DAELIM IND. CO.,LTD.	KOREA	2014
MPPU PROJECT	STACK / HEATER	STYROLUTION	THAILAND	2014
A1 PROJECT	FILTER	KPX Green Chemical	KOREA	2014
WASTEWATER TREATMENT DRYING	DRYER	CHEON-IL CHEMICAL	KOREA	2015
SUPERCONDUCTING FAULT CURRENT LIMITER	VESSEL	KIMM	KOREA	2015
BIOGAS ENERGY PROJECT	VESSEL	UIJEONGBU CITY	KOREA	2015
STEAM GENERATOR PROJECT	HEATER	KEPCO ENG	KOREA	2015
J-N20 PLANT EXPANSION PROJECT	TOTAL EQUIPMENT	WONIK MATERIALS	KOREA	2015
SRF LN2 SEPARATOR PROJECT	VESSEL (HIGH PRESSURE)	NIER	KOREA	2015
LP&HP HEATER	HEATER	BESAT POWER PLANT	KOREA	2015
SUNNY PROJECT	DRYER	SOLVAY	KOREA	2015
RO-COMP. CALORIMETER PROJECT	VESSEL	SAMSUNG	KOREA	2015
BAS-514H PROJECT	H/EX.	OCI	KOREA	2015
A PROJECT	REACTOR / VESSEL	ROSS EQUIP.	USA	2015
REACTOR PROJECT	REACTOR	HANSEO CHEM.	KOREA	2015
FFC MIXING SYSTEM PROJECT	VESSEL	DOOSAN	KOREA	2015
DANYANG PLANT PROJECT	VESSEL	HANIL CEMENT CO.,LTD.	KOREA	2016
UK3 PROJECT	BIO REACTOR	HITACHI	JAPAN	2016
EDISON III PROJECT	BIO REACTOR	SAMSUNG BIOLOGICS	KOREA	2016
CP-2 LM-V PROJECT	C.R.T	HUVIS	KOREA	2016
TOTAL PIPING SYSTEM	PIPING	KGS	KOREA	2016
REACTOR PROJECT	REACTOR	HANSEO CHEM.	KOREA	2016
LN2 SEPARATOR PROJECT	VESSEL (HIGH PRESSURE)	NIER	KOREA	2016
FILTER HOUSING PROJECT	FILTER	ELCOM KOREA LIMITED	KOREA	2016
EDISON III PROJECT	BIO REACTOR	SAMSUNG BIOLOGICS	KOREA	2016
S PROJECT	VESSEL / C.R.T / H/EX.	WONIK MATERIALS	KOREA	2016

NAME OF PROJECT	DESCRIPTION	CLIENT	SITE	YEAR
E PROJECT	REACTOR / TOWER / VESSEL	DAELIM	KOREA	2016
100,000 MTY PB2 PLANT	REACTOR	DAELIM	KOREA	2016
HANMI BIOPANT PROJECT	BIO REACTOR	HANMI PHARM CO.,LTD.	KOREA	2016
UK3 PROJECT	BIO REACTOR	HITACHI	JAPAN	2016
50L PURIFICATION SYSTEM	TOTAL	HANSOL CHEMICAL	KOREA	2016
C-PURIFICATION SYSTEM	VESSEL / HEX.	DUKSAN UMT	KOREA	2016
HCDS SYNTHESIZER SYSTEM	VESSEL	DUKSAN UMT	KOREA	2016
HIGH EFFICIENCY CYCLONE SEPARATOR	VESSEL	HANWHA	KOREA	2016
YEOJU PLANT	AIR HEADER	HANIL CEMENT CO.,LTD.	KOREA	2016
DREAM PROJECT	BIO REACTOR	POLUS	KOREA	2017
RO-COMP. CALORI JECTION	VESSEL	SAMSUNG	KOREA	2017
SHIN-KORI NUCLEAR POWER PLANT	VESSEL / TANK	"KHNP (한국수력원자력)"	KOREA	2017
J-N20 1800MTPY EXPANSION	H/EX.	WONIK MATERIALS	KOREA	2017
CIRCULATING POWER GENERATION	TEST BED	ULSAN UNIVERSITY	KOREA	2017
FLUID REACTOR	TEST BED	KAIST	KOREA	2017
RESIDUE UPGRADING COMPLEX	VESSEL / TANK	S-OIL	KOREA	2017
BIO PLANT NO.2 FACTORY	BIO REACTOR	HANMI PHARM	KOREA	2017
STERILIZED INCUBATOR	BIO REACTOR	CHUNGCHEONGBUK-DO.	KOREA	2017
NTS PROJECT	VESSEL	KUKDO CHEMICAL	KOREA	2017
PRESSURIZATION CHAMBER	TEST BED	SAMSUNG	KOREA	2017
BIO KOMBINAT	REACTOR / H/EX.	GS CALTEX	KOREA	2017
PHEONIX	BIO REACTOR	CELLTRION	KOREA	2017
SPENT CATALYST RARE METAL RECOVERY	PILOT PLANT	KIGAM (한국지질자원연구소)	KOREA	2018
KORENO KT-Z PROJECT	REACTOR / H/EX.	KRICT (한국화학연구원)	KOREA	2018
HASTELLOY REACTOR /H/EX.	REACTOR / H/EX.	CHEMTROS	KOREA	2018
IMPORT OMMODITY(BIO)	REACTOR	BIOZEEN	INDIA	2018
HCDS EP FACILITIES PROJECT	VESSEL / SYSTEM	DS TECOPIA	KOREA	2018
DK-PROJECT	REACTOR / H/EX.	DK PHARM	KOREA	2018
PURIFICATION SYSTEM	VESSEL / PIPING	DUKSAN UMT	KOREA	2018
GAS PURIFIER	VESSEL	LEADERS & GLOBAL	KOREA	2018
PILOT YSTEM	TOTAL	WONIK MATERIALS	KOREA	2018

NAME OF PROJECT	DESCRIPTION	CLIENT	SITE	YEAR
T-PROJECT	REACTOR / H/EX.	CERES R&D	KOREA	2019
NCK B2 PROJECT	VESSEL	NCK	KOREA	2019
ACTIVATED CARBON 20L REACTOR SYSTEM	REACTOR	HI AIR KOREA	KOREA	2019
MONOMER REACTOR SYSTEM	REACTOR	HANSOL	KOREA	2019
REACTOR 12m SYSTEM	REACTOR / H/EX.	SHINSUNG MATERIALS	KOREA	2019
NITROGEN GENERATOR INSTALLATION	VESSEL	HYUNDAI MOTOR UIWANG R&D CENTER	KOREA	2019
PYEONGTAEK RESIN PLANT PHASE 2	VESSEL	JEVISCO	KOREA	2019
PURIFICATION VESSEL	VESSEL	3C FRANCE	FRANCE	2019
RETORT SYSTEM	AUTOCLAVE	CST	CHINA	2019
REACTOR SYSTEM	REACTORS & HEAT EXCHANGER	DAEDAL	CHINA	2019
FERMENTAL SYSTEM	FERMENTAL VESSEL	SATORIOUS	GERMANY	2019
FERMENTAL SYSTEM	FERMENTAL VESSEL	SATORIOUS	INDIA	2019
CIP PROCESS	HEAT EXCHANGERS	BOSH	GERMANY	2019
DRYER SYSTEM	DRYER	HAKO PLAN	JAPAN	2019
REACTOR SYSTEM	REACTORS	HITACHI	JAPAN	2019
RETORT SYSTEM	AUTOCLAVE	DFT	GERMANY	2019
RETORT SYSTEM	AUTOCLAVE	STERIFLOW	FRANCE	2019
BIO PROCESS	CLEAN VESSEL	M-PRO TECH	FRANCE	2019
REACTOR SYSTEM	REACTORS & HEAT EXCHANGER	JINHEUNG	CHINA	2019
AUTO CLAVE	AUTO CLAVE	THEMATEC	JAPAN	2019
CIP PROCESS	HEAT EXCHANGERS	TECH SOLUTION	CHINA	2019
FOOD SYSTEM	PEELER	JUNGWOO	NETHERLAND	2019
HEAT PROCESS	HEAT EXCHANGER	VEOLIA	ITALIA	2019
DRYER SYSTEM	DRYER MACHINE	GEM-BIO	JAPAN	2019
PHC1 PROJECT	SILO	HUVIS	KOREA	2019
REACTOR SYSTEM	REACTORS & HEAT EXCHANGER	DOOYOUNG	CHINA	2019
IN-PROJECT	AUTO CLAVE	INTERCONSTEC	JAPAN	2019
CIP PROCESS	HEAT EXCHANGER	EKL	FRANCE	2019
EGT SENSOR TEST BED	TEST BED	KHNP(한국수력원자력)	KOREA	2019
COALESCE FILTER TEST BED	TEST BED	ADD (국방과학연구소)	KOREA	2019
RO-COMP. CALORIMETER	VESSEL	SAMSUNG	KOREA	2019

NAME OF PROJECT	DESCRIPTION	CLIENT	SITE	YEAR
MFG-8 WuXi SHIJIAZHANG	BIO TANK	WUXI BIOLOGICS	CHINA	2020
FK3 PROJECT	VESSEL	HITACHI PLANT SERVICE	JAPAN	2020
REACTOR SYSTEM	REACTOR / VESSEL / H/ EX.	DONGYANG PNE	KOREA	2020
SR RECOVERY PROJECT	H/EX.	DAEWOONG BIO	KOREA	2020
PM1 CORRUGATING MEDIUM PAPER	VESSEL	경산제지주	KOREA	2020
REACTOR SYSTEM	REACTOR / H/EX.	현대원프리머	KOREA	2020
HONGIK PROJECT	REC.VESSEL	HONGIK	KOREA	2020
YOUNGCHANG CHEMICAL PLANT 4	VESSEL	영창케미칼	KOREA	2020
VERTICAL PLANETARY MIXER	MIXER VESSEL	HANWHA	KOREA	2020
CIP PROCESS	HEAT EXCHANGER / CONDENSER	YOORYOUNG PHARMACY	GERMANY	2020
JW-PROJECT	AUTO CLAVE	JW PHARMACY	FRANCE	2020
IN-PROJECT	AUTO CLAVE	INTERCONSTEK	CHINA	2020
JWO-PROJECT	STEAM PEELER & ACCULULATOR	JUNGWOO	NETHERLAND	2020
TMT-PROJECT	AUTO CLAVE	THEMATEK	GERMANY	2020
SYB-PROJECT	REACTOR & CONDENSER	SAMYANG BIO	CHINA	2020
JTM-PROJECT	H/EX / REACTANGLER CLAVE	JETEMA	SWEDEN	2020
SC-PROJECT	REACTOR & CONDENSER	SK CHEM	GERMANY	2020
TS-PROJECT	HEAT EXCHANGER / CONDENSATE TANK	TS TECH	CHINA	2020
HEAT EXCHANGER	HEAT EXCHANGER / STORAGE TANK	KOREA UNITED PHARMACY	CHINA	2020
YM-PROJECT	REACTOR	YAMAGEN	JAPAN	2020
CHEMICAL TOWER	TOWER	HANWHA E&C	CHINA	2020
UHT PROCESS	UHT	SAMYOOK FOOD	ITALY	2020
BA-PROJECT	AUTO CLAVE	BINEX	AUSTRIA	2020
SKB-PROJECT	BIO JACKET VESSEL	SK BIO	KOREA	2020
CHEMICAL PROCESS	EVAPORATOR	SAMYANG BIO	KOREA	2020
FERMENTAL PROCESS	FERMENTAL VESSEL	LG CHEMICAL	INDIA	2020
PHARMACY PROCESS	STEAM GENERATOR	KOREA UNITED PHARM.	CHINA	2020
SEPARATOR PROCESS	SEPARATOR	SAMSUNG BIO	GERMANY	2020
CHEMICAL PROCESS	EVAPORATOR	SAMYANG INNOCHEM	GERMANY	2020
FOOD PROCESS	UHT	SAMYOOK FOOD	ITALY	2020
SCORPION PROJECT	VESSEL / REACTOR	UJL INC.	KOREA	2020

NAME OF PROJECT	DESCRIPTION	CLIENT	SITE	YEAR
DEEP-SEA WIRE TEST	AUTO CLAVE	LS CABLE & SYSTEM LTD.	KOREA	2020
HIGH-PRESSURE / TEMP-PROJECT	VESSEL	KNT	KOREA	2020
CHEMICAL PRODUCT SYSTEM	REACTOR / VESSEL / H/ EX	CCCE	KOREA	2020
CHEMICAL LINE SYSTEM	CONDENSER	DS CHEMSOL	KOREA	2020
BATTERY METEALS	VESSEL	UMICORE	KOREA	2020
LSP PROJECT	LSP REACTOR	HUVIS	KOREA	2020
MAINTENANCE SYSTEM	H/EX / VESSEL / PIPING	SUWON ENVIRONMENT AGENCY	KOREA	2020
FACTORY EQUIPMENT SYSTEM	REACTOR / RETORT	PEPTRON	KOREA	2020
PROCESS SYSTEM	VESSEL	SUNGEEL HITECH	KOREA	2020
NEW PROCESS PROJECT	C.R.T. / VESSEL	JEVISO	KOREA	2020
EDISON-3 PROJECT	BIO-TANK / REACTOR	SAMSUNG BIOLOGICS	KOREA	2020
FERMENTER LINE PROJECT	FERMENTOR	CJ CHEILJEDANG CORP	KOREA	2020
POLYMERIZATION PROJECT	SILO	HUVIS	KOREA	2020
TEST EQUIPMENT	VESSEL.	KIER	KOREA	2020
CEMENT PROJECT	AIR HEADER	HANIL CEMENT	KOREA	2020
PI CONSTRUCTION PROJECT	VESSEL / REFLUX TANK	DL E&C	KOREA	2021
GL PROJECT	REACTOR	SUNGIL	CHINA	2021
RO-COMP PROJECT	VESSEL	SAMSUNG ELECTRONICS	KOREA	2021
DRYING FACILITY PROJECT	DRYER / VESSEL	SEOUL CITY	KOREA	2021
BRP PROJECT	AGING TANK / H/EX	ECOPRO	KOREA	2021
CHEMICAL SYSTEM	REACTOR / TANK	SAKURANOMIYA CHEMICAL	KOREA	2021
DOUST COLLECTOR PROJECT	VESSEL / COLLECTOR	HYUNDAI SAMHO HEAVY INDUSTRIES	KOREA	2021
CHAMBER SYSTEM	HEAT EXCHANGER	BINEX	ITALY	2021
FERMENTER SYSTEM	FERMENTER VESSEL	NOROO HOLDINGS	INDIA	2021
SMT VESSEL PROJECT	REACTOR / VESSEL	PI ADVANCED MATERIALS	KOREA	2021
N-PROJECT	FEED GAS PRE-COOLER	TEMCO	KOREA	2021
SK PROJECT	MIXER TANK	ECELL	KOREA	2021
HELUIM SYSTEM	VESSEL	JH ENG	KOREA	2021
FILTER SYSTEM	VESSEL	TOPS	KOREA	2021
DISTILLATION SYSTEM	HEAT EXCHANGER	YOORYOUNG PHARM	GERMANY	2021

NAME OF PROJECT	DESCRIPTION	CLIENT	SITE	YEAR
ASPHALT RUBBER SYSTEM	HEAT EXCHANGER	POINIX	USA	2021
EDISON-PROJECT	BIO REACTOR / VESSEL	SAMSUNG BIOLOGICS	KOREA	2021
SPECIA-PROJECT	HEAT EXCHANGER / COOLER	TY PFAUDLER	GERMANY	2021
SK PROJECT	MIXER TANK	ECELL	KOREA	2021
FOOD STERILIZER SYSTEM	AUTO CLAVE	HARIM	GERMANY	2021
SUI-PLANT FILTER HOUSING PROJECT	FILTER HOUSING	AEKYUNG CHEMICAL	KOREA	2021
KOLMAR PROJECT	MIXER TANK	ECELL	KOREA	2021
WASTE WATER BOILER SYSTEM	BOILER PKG	SAMPYO CEMENT	CHINA	2021
DONGJIN CHEMICAL BUYEO PLANT PROJECT	REACTOR / H / EX / RECEIVER TANK	DONGJIN CHEMICAL	KOREA	2021
H2 SYSTEM	ACCUMULATOR	DOOSAN FUELCELL	CANADA	2021
150HP DISSOLVER PROJECT	BUCKET STRAINER	DAEKWANG HIGHPOLYMER	KOREA	2021
DISTILLATION SYSTEM	HEAT EXCHANGER	EYON PHARM.	GERMANY	2021
H2 COLUMN SYSTEM	COLUMN / TANK	DAEJOO ELECTRONIC MATERIALS	KOREA	2021
NA50 PROJECT	REACTOR	ANP CORP.	KOREA	2021
DISTILLATION SYSTEM	HEAT EXCHANGER	BMI	GERMANY	2021
EVAPORATOR SYSTEM	VESSEL	THE O FOUR	ITALY	2021
BIO PROJECT	WATER TANK	SAMSUNG BIO	GERMANY	2021
FILTER HOUSING PROJECT	FILTER HOUSING	ECOPRO INNOVATION	KOREA	2021
ASPHALT RUBBER SYSTEM	BOILER	POINIX	USA	2021
DISTILLATION SYSTEM	HEAT EXCHANGER	HUONS	GERMANY	2021
N2 CHEMICAL TANK	TANK	KUMHO PETROCHEMICAL	KOREA	2021
SB01 PROJECT	JACKET VESSEL	CELLTRION	KOREA	2021
DISTILLATION SYSTEM	HEAT EXCHANGER	DONG-A	GERMANY	2021
AHF SYSTEM	VESSEL	ENF TECHNOLOGY	CHINA	2021
100ML PROJECT	BIO VESSEL	KUMHO PETROCHEMICAL	KOREA	2021
STEAM CONCRET SYSTEM	DRAIN TANK	GIANT	CHINA	2021
C-2 PROJECT	REACTOR / VESSEL	HYOSUNG	KOREA	2021
P-PROJECT	BIO REACTOR / TANK	DAEWON HEALTHCARE	KOREA	2021
BIO PROJECT	WATER TANK	SAMSUNG BIO	GERMANY	2021
QR01 PROJECT	BIO VESSEL	HANMI	KOREA	2021

NAME OF PROJECT	DESCRIPTION	CLIENT	SITE	YEAR
SEMI-CONDUCTOR SYSTEM	REACTOR	NCK	JAPAN	2021
N2 PKG SYSTEM	VESSEL	CARTOOLS	CHINA	2021
HIGH PRESSURE REACTOR 200L	REACTOR	CHEMTROS	KOREA	2021
AIR COMPRESSOR PKG	AIR RECEIVER TANK	BINGGRAE	KOREA	2021
SMELTING PROCESS PROJECT	TOTAL SYSTEM	KIGAM	KOREA	2021
QR02 PROJECT	BIO VESSEL	CELLTRION	KOREA	2021
FORM SPONGE SYSTEM	REACTOR	KM&I	GERMANY	2021
N-PROJECT	BUFFER TANK	TEMCO	KOREA	2021
DISTILLATION SYSTEM	HEAT EXCHANGER	HONEX	CHINA	2021
SK PROJECT	MIXER TANK	SK BIO	KOREA	2021
NMP PURIFICATION SYSTEM	TOWER / VESSEL / H/EX	KOKAM	KOREA	2021
DANGJIN THERMAL POWER 1-4 PROJECT	REACTOR / H/EX	KOREA EAST-WEST POWER	KOREA	2021
WASTE WATER BOILER SYSTEM	BOILER	NONGSHIM	CHINA	2021
EC05 PROJECT	BIO VESSEL	CELLTRION	KOREA	2021
FOOD STERILIZER SYSTEM	AUTO CLAVE	LOTTE FOOD	FRANCE	2021
REACTOR SYSTEM	REACTOR / H/EX	DS CHEMSOL	KOREA	2021
FERMENTER SYSTEM	FERMENTER VESSEL	INTRON	GERMANY	2021
EC010 PROJECT	BIO VESSEL	CELLTRION	KOREA	2021
PLASTIC PRODUCTION SYSTEM	HEAT EXCHANGER	INEOS	GERMANY	2021
PG-4 PROJECT	REACTOR / VARNISH TANK	PI ADVANCED MATERIALS	KOREA	2021
DISTILLATION SYSTEM	HEAT EXCHANGER	JANSSEN	GERMANY	2021
EDISON IV PROJECT	BIO REACTOR	SAMSUNG BIOLOGICS	KOREA	2021
WASTE INCINERATION FACILITY PROJECT	AIR PREHEATER	JEJU PROVINCE DEVELOPMENT	KOREA	2021
CMDL PLANT EXPANSION PROJECT	REACTOR / H/ EX / RECEIVER TANK	CMDL	KOREA	2021
DISTILLATION SYSTEM	BIO VESSEL	KOREA UNITED PHARM	CHINA	2022
MACHINING SPOT	P.C.I FEED HOPPER CONE	POSCO	KOREA	2022
SHIPPING PIPING PROJECT	PIPING / TANK	POINIX INC.	KOREA	2022
FERMENTER SYSTEM	VESSEL	KNBS	USA	2022
CHEMICAL SYSTEM	BIO VESSEL / TANK	DONG-A PHARM	KOREA	2022
T-PROJECT	CONDENSER / SEPARATOR	DONGSUNG CHEMICAL	KOREA	2022
REACTOR SYSTEM	BIO VESSEL	MI PHARM	CHINA	2022

NAME OF PROJECT	DESCRIPTION	CLIENT	SITE	YEAR
FOOD STERILIZER SYSTEM	VESSEL	CJ FOOD	USA	2022
V-PROJECT	STORAGE TANK	KTL	KOREA	2022
H2 PSA SYSTEM PROJECT	ADSORBER COLUMN / TANK	EN2CORE TECH	KOREA	2022
UHT PKG SYSTEM	VESSEL	SAMYANG HOLDINGS	GERMANY	2022
VACUUM SYSTEM	VESSEL	KOREA LOST WAX	USA	2022
BIO SYSTEM	FILTER HOUSING / VESSEL	KUKDO CHEMICAL	KOREA	2022
OIL PURIFICATION SYSTEM	TUBE CLUSTER	S-OIL	TAIWAN	2022
WASTE WATER FILTERING SYSTEM	HEAT EXCHANGER	THE O FOUR	ITALY	2022
SOLBRAIN PROJECT	VESSEL / RECOVERY TANK	SOLBRAIN	KOREA	2022
BIO PROJECT	BIO REACTOR	CELLTRION	KOREA	2022
STEAM PJG SYSTEM	BIO VESSEL	FROM BIO	GERMANY	2022
UHT PJG SYSTEM	HEAT EXCHANGER	SAMYANG HOLDINGS	GERMANY	2022
H1 PROJECT	HEAT EXCHANGER	TEMC	KOREA	2022
H/EX MANUFACTURE PROJECT	HEAT EXCHANGER	WELCRON HANTEC	KOREA	2022
VACUUM COOLING SYSTEM	AUTO CLAVE	SHIMADZU	CHINA	2022
E4-PROJECT	C.R.T.	HYOSUNG CHEMICAL	KOREA	2022
STS316L REACTOR SYSTEM	REACTOR / H / EX / RECEIVER TANK	CHEMTROS	KOREA	2022
CMDL PLANT EXPANSION	REACTOR / H / EX	CMDL	KOREA	2022
LG PROJECT	MIXING TANK / VESSEL	LG ENERGY SOLUTION	GERMANY	2022
CHEMICAL SYSTEM	BIO VESSEL	KUMHO MITSUI CHEMICALS, INC.	KOREA	2022
AIR FILTER PROJECT	FILTER HOUSING	SAMSUNG DISPLAY	KOREA	2022
DISTILLATION SYSTEM	HEAT EXCHANGER	STGEN BIO	GERMANY	2022
REACTOR SYSTEM	REACTOR	LG CHEM	SWITZERLAND	2022
STS304 PROJECT	HOT OIL TANK / RECEIVER TANK	CHEMTROS	KOREA	2022
BIO PROJECT	BUFFER PREP TANK / BIOREACTOR	CELLTRION	KOREA	2022
KIA MOTORS TANK PROJECT	STORAGE TANK	KIA CORP	KOREA	2022
DISTILLATION SYSTEM	H/EX / SEPARATOR	DM BIO	GERMANY	2022
SINGLE USE MIXER SYSTEM	DOUBLE JACKET VESSEL	DONG-A PHARM	KOREA	2022
REACTOR PROJECT	VESSEL / TANK / DRUM / SEPARATOR	META BIOMED	KOREA	2022
DISTILLATION SYSTEM	H/EX / PROCESS VESSEL	RF BIO	GERMANY	2022
DAEJEON PLANT PROJECT	REACTOR / H / EX / RECEIVER TANK	DONGYANG	KOREA	2022

NAME OF PROJECT	DESCRIPTION	CLIENT	SITE	YEAR
PG5 PROJECT	REACTOR	PI ADVANCED MATERIALS	KOREA	2022
DISTILLATION SYSTEM	STERILIZER	BINEX	AUSTRIA	2022
MDI PLANT PROJECT	BIO VESSEL	KUMHO MITSUI CHEMICALS CORP	KOREA	2022
HEAT EXCHANGER SYSTEM	HEAT EXCHANGER	METHISON GAS	USA	2022
CO2 PSA SYSTEM PROJECT	STRUCTURE / PIPING / VESSEL	HYUNDAI ROTEM	KOREA	2022
LITHIUM SYSTEM	VESSEL	POSCO HOLDINGS	GERMANY	2022
BIO PROJECT	BIO REACTOR / STORAGE TANK	CELLTRION	KOREA	2022
LGESOC2 1P PROJECT	COOLER / REBOILER / H/ EX	LG ENERGY SOLUTION	KOREA	2022
HSPF PROJECT	REACTOR / VESSEL	P&O CHEMICAL	KOREA	2022
MH-PROJECT	C.R.T.	KUKDO CHEMICAL	KOREA	2022
EPOXY PILOT INSTALLATION PROJECT	BIO VESSEL / STERILIZER	KUMHO P&B CHEMICALS	KOREA	2022
POSCO CONTINENTAL	VESSEL	POSCO HOLDINGS	GERMANY	2022
WASTEWATER TREATMENT FACILITY PROJECT	PROCESS VESSEL	HYUNDAI STEEL	KOREA	2022
PITK PROJECT	REACTOR / VESSEL	DAEWON PHARMACEUTICAL	KOREA	2022
NORTHVOLT D. S-3	BINDER MIXER / STORAGE TANK	NORTHVOLT	KOREA	2022
POLY-E PROJECT	VESSEL / FILTER HOUSING	SOLBRAIN	KOREA	2022
OXO RTO-PROJECT	RTO / FERMENTER	LG CHEMICAL	KOREA	2022
BIO PROJECT	BIO VESSEL	SAMSUNG BIOLOGICS	KOREA	2022
DRYER PKG SYSTEM	VESSEL	TAEKWANG	JAPAN	2022
POSCO LITHIUM SOLUTION	HEAT EXCHANGER	POSCO HOLDINGS	GERMANY	2022
T20 PROJECT	REACTOR / STORAGE TANK	LG CHEM.	KOREA	2022
NH3 VPSA PROJECT	TOTAL EQUIPMENT	KIER	KOREA	2022
J-PROJECT	VESSEL	KIER	KOREA	2022
LINE-PROJECT	AIR FLOTATION	LOTTE CHEMICAL	KOREA	2022
OCI STC PROJECT	REACTOR / H/EX	OCI	KOREA	2022
POLYMER PROJECT	STORAGE TANK	LG CHEMICAL	KOREA	2022
V.E. PROJECT	WATER COOLER	LOTTE CHEMICAL	KOREA	2022
DUST PNEUMATIC CONVEYING SYSTEM	TANK / VESSEL	POSCO	KOREA	2022
VAPOR BOILER SYSTEM	BOILER	SAMSHIN	USA	2022
DISTILLATION SYSTEM	HEAT EXCHANGER	DONG-A PHARM.	GERMANY	2022
PISTON PRESSURE VESSEL	VESSEL / DRYER	SK GEO CENTRIC	KOREA	2022

NAME OF PROJECT	DESCRIPTION	CLIENT	SITE	YEAR
EDISON PROJECT	BIO REACTOR / STERILIZER	SAMSUNG BIOLOGICS	KOREA	2023
AU PROJECT	AUTOCLAVE / H/EX	CIS CHEMICAL	KOREA	2023
STEAM COOKER SYSTEM	VESSEL / DRYER	KAJIWARA	JAPAN	2023
STEAM BOILER PKG	STEAM BOILER	KBR	USA	2023
T1 PROJECT	EVAPORATOR	LG CHEM	KOREA	2023
REACTOR SYSTEM	REACTOR	CMDL	KOREA	2023
BIO PROJECT	HOLD VESSEL	SAMSUNG BIOLOGICS	KOREA	2023
UHT SYSTEM	HEAT EXCHANGER	GEA TDS	GERMANY	2023
CHEMICAL SYSTEM	VESSEL	MIWON CHEM	USA	2023
POLY-E PROJECT	STORAGE TANK	SOLBRAIN	KOREA	2023
BPA POWDER PROJECT	TRANSPORTER	KUMHO P&B CHEMICALS	KOREA	2023
QL-PROJECT	C.R.T.	CHEMTRONICS	KOREA	2023
CHEMICAL PROCESS	DRYER / STORAGE TANK	CIS CHEMICAL	GERMANY	2023
VESSEL PROJECT	H/EX / AUTOCLAVE / REACTOR	HUMEDIX	KOREA	2023
LITHIUM SYSTEM	VESSEL	POSCO	ITALY	2023
LITHIUM SYSTEM	VESSEL	SUNGIL HITEK	CHINA	2023
DISTILLATION SYSTEM	H/EX / STERILIZER	STGEN BIO	GERMANY	2023
DS-1 PROJECT	REACTOR / BUFFER TANK	NORTHVOLT	KOREA	2023
SEJONG PLANT PROJECT	VESSEL	KCC GLASS CORP	KOREA	2023
CHEMICAL SYSTEM	HEAT EXCHANGER	HOSOKAWA	JAPAN	2023
CHEMICAL SYSTEM	EVAPORATOR	WUXI LIMA	CHINA	2023
LITHIUM SYSTEM	VESSEL	POSCO	TURKIYE	2023
BIO PROJECT	BIO VESSEL	DAEWON PHARMACEUTICAL	KOREA	2023
GLASS FIBER NO.2 PROJECT	PROCESS VESSEL	KCC GLASS CORP	KOREA	2023
INSTALLATION OF USER TANK PROJECT	C.R.T.	KUMHO MITSUI CHEMICALS	KOREA	2023
BOILER SYSTEM	BOILER	ENDORFF	USA	2023
HF PH2 PROJECT	TOWER / REACTOR / STEAM HEADER	ENF TECHNOLOGY	KOREA	2023
BIO SYSTEM	VESSEL	TDS	GERMANY	2023
CHEMICAL PROCESS	TOWER / PROCESS VESSEL	CIS CHEMICAL	KOREA	2023
REACTOR SYSTEM	REACTOR	CHEMTROS	KOREA	2023
A-PROJECT	VESSEL / MIXER / DRUM	SAMSUNG SDI	KOREA	2023

NAME OF PROJECT	DESCRIPTION	CLIENT	SITE	YEAR
GRAPHENE PILOT PLANT	REACTOR	JNC MATERIALS	KOREA	2023
FTS PROJECT	REACTOR / TANK /	DNF	KOREA	2023
STEAM COOKER SYSTEM	PRESSURE VESSEL	KAJIWARA	JAPAN	2023
STEAM BOILER PKG	POWER BOILER	KBR	USA	2023
UHT SYSTEM	HEAT EXCHANGER	GEA TDS	GERMANY	2023
CNT DISPERSION PROJECT	MIXER BOWL	SAMSUNG SDI	KOREA	2023
CHEMICAL SYSTEM	EVAPORATOR	MIWON CHEM	USA	2023
DISTILLATION SYSTEM	HEAT EXCHANGER	STGEN BIO	GERMANY	2023
CHEMICAL SYSTEM	H/EX / STORAGE TANK	HOSOKAWA	JAPAN	2023
H2 PSA SYSTEM	HIGH-PURITY HYDROGEN SEPARATION& PURIFICATION SYSTEM	KTL	KOREA	2023
DP010 PROJECT	NITROGEN PURIFICATION COLUMN	SK HYNIX INC	KOREA	2023
CHEMICAL SYSTEM	EVAPORATOR	WUXI LIMA	CHINA	2023
C PROJECT	METHANOL ADSORPTION TOWER	DAEJOO ELECTRONIC MATERIALS	KOREA	2023
DRINK PRODUCE SYSTEM	HEAT EXCHANGER	DONGWON SYSTEMS	CHINA	2023
CS050(020) PROJECT	NITROGEN PURIFICATION COLUMN	WONIK MATERIALS	KOREA	2023
CLEAN WATER SYSTEM	HEAT EXCHANGER	BINEX	ITALY	2023
BIO SYSTEM	REACTOR	SK BIO	USA	2023
LAr PROJECT	LIQUID ARGON CRYOGENIC CHAMBER	SEOUL NATIONAL UNIVERSITY	KOREA	2023
FOOD PRODUCE SYSTEM	AUTO CLAVE	LOTTE FOOD	FRANCE	2023
PHARMACY SYSTEM	HEAT EXCHANGER	KOREA UNITED PHARM.	CHINA	2023
TaV PROJECT	HEAVY TAR SALES FACILITY	HYUNDAI STEEL	KOREA	2023
NO.2 MNB PROJECT	TANK / H/EX	DAEWOO E&C	KOREA	2023
PHARMACY SYSTEM	PRESSURE VESSEL	HANMI PHARM.	GERMANY	2023
BIO SYSTEM	HEAT EXCHANGER	SAMSUNG BIO	JAPAN	2023
N-1(Maf) PROJECT	AMMONIA PRESSURE VESSEL / STORAGE TANK	HANWHA CORPORATION	KOREA	2023
LSP PROJECT	RAW MATERIAL FEEDING SYSTEM	LG PRI	KOREA	2023
FOOD PRODUCE SYSTEM	AUTO CLAVE	DONGWON	FRANCE	2023
FOOD OIL SYSTEM	EVAPORATOR	DONGSUH	MALAYSIA	2023
PILOT PLANT PROJECT	PROCESS VESSEL	ISU SPECIALTY CHEM.	KOREA	2023
CHEMICAL SYSTEM	REACTOR	MIJOOENBICHEM	CHINA	2023
P.C.I PROJECT	HIGH-PRESSURE GAS FEED HOPPER	POSCO	KOREA	2023

NAME OF PROJECT	DESCRIPTION	CLIENT	SITE	YEAR
3MS PROJECT	3MS SYNTHESIS SYSTEM	SOLEMATERIALS	KOREA	2024
PHARMACY RESEARCH SYSTEM	H/EX / FERMENTER	YOYOYOUNG PHARMACY	GERMANY	2024
FOOD PRODUCE SYSTEM	AUTO CLAVE	HARIM FOOD	FRANCE	2024
AFTER COOLER PROJECT	H/EX / DRAIN TANK	SAMYANG HOLDINGS CORP.	KOREA	2024
C2H2 PROJECT	HIGH-PURITY C2H2 FILLING SYSTEM	TAEKYUNG ECO	KOREA	2024
CHEMICAL SYSTEM	PRESSURE VESSEL	GLCHEM	CHINA	2024
PROCESS MILK SYSTEM	UHT / STERILIZER	BINGGRAE	GERMANY	2024
YEP-VI PROJECT	HEATER / EVAPORATOR	KUMHO POLYCHEM	KOREA	2024
HE PROJECT	H/EX / FILTER / HARVEST TANK	HUMEDIX	KOREA	2024
SECONDARY CELL	PROCESS VESSEL	INNOX	CHINA	2024
A144 PROJECT	HIGH-PURITY HELIUM CHARGING UNIT	SK HYNIX INC.	KOREA	2024
RECYCLE PLASTIC SYSTEM	REACTOR / BIO VESSEL	LG CHEMICAL	SWEDEN	2024
BIO SYSTEM	REACTOR / BIO VESSEL	SK BIO	USA	2024
A145 PROJECT	HIGH-PRESSURE NITROGEN CHARGING SYSTEM	TEMC	KOREA	2024
A148 PROJECT	NITROGEN PURIFICATION SYSTEM	SAMSUNG SDI	KOREA	2024
CONCRETE SYSTEM	BOILER	POINIX	USA	2024
CN200 PROJECT	HIGH-PRESSURE HYDROGEN PURIFICATION SYSTEM	SAMSUNG SDI	KOREA	2024
HSC COSMOS PROJECT	BIOVESSEL	HANWHA SOLUTIONS	KOREA	2024
BIO SYSTEM	BIO VESSEL / TOWER	SAMSUNG BIO	FRANCE	2024
DCD-401 PROJECT	MELT POLYMERIZATION REACTOR	META BIOMED	KOREA	2024
P.C.I PROJECT	LOW-VOLATILITY PCI STORAGE TANK	POSCO	KOREA	2024
CHEMICAL SYSTEM	AUTO CLAVE / DRYER	HYOSUNG	CHINA	2024
BH-1 PROJECT	NOx EMISSION REDUCTION SYSTEM	LG CHEM	KOREA	2024
DE-PROJECT	REACTOR / TOWER	DONGIN CHEM	KOREA	2024
SAL DE ORO PROJECT	PROCESS VESSEL	POSCO	KOREA	2024
RF PROJECT	ETHYLENE GLYCOL STORAGE TANK	KUMHO PETROCHEMICAL	KOREA	2024
PAPER PRODUCE SYSTEM	PROCESS VESSEL	MOORIM	CHINA	2024
E PROJECT	MOISTURE SEPARATION SYSTEM	OCI & KUMHO	KOREA	2024
GMP PROJECT	H/EX / STERILIZER	DAEWOONG BIO	KOREA	2024
RECHARGEABLE BATTERY SYSTEM	HEAT EXCHANGER	VEOLIA	ITALY	2024
HT PROJECT	VACUUM SYSTEM	HUMANTEK	KOREA	2024

NAME OF PROJECT	DESCRIPTION	CLIENT	SITE	YEAR
ENVIRONMENTAL ANALYSIS LAB VENT SYSTEM	TOWER	SK SPECIALITY	KOREA	2024
C-PROJECT	STERILIZER / CYCLONE	DAEWOONG	KOREA	2024
HM-PROJECT	STORAGE TANK / REACTOR / H/EX / AUTO CLAVE	HUMEDIX	KOREA	2024
PAPER PRODUCE SYSTEM	PROCESS VESSEL	MOORIM	CHINA	2024
GLP PROJECT	GLYCOLIDE PRODUCTION SYSTEM	POLY BIOTECH	CHINA	2024
CS500 PROJECT	NITROGEN PURIFICATION COLUMN	SK HYNIX INC.	KOREA	2024
CMN250 PROJECT	OXIDATION SYSTEM	SAMSUNG SDI	KOREA	2024
LGESOC2 1P PROJECT	CONDENSER / H/EX	LG ENERGY SOLUTION	KOREA	2024
RECHARGEABLE BATTERY SYSTEM	HEAT EXCHANGER	VEOLIA	ITALY	2024
HOSPITAL RESEARCH SYSTEM	CHAMBER	BUSAN UNIVERSITY	ITALY	2024
HL-PROJECT	TANK / STERILIZER	HANLIM PHARM.	KOREA	2024
CS200 PROJECT	H2 / N2 / NH3 PURIFIERS	SAMSUNG SDI	KOREA	2024
FOOD PRODUCE SYSTEM	DRYER / STERILIZER	HARIM FOOD	DENMARK	2024
CHEMICAL SYSTEM	REACTOR / BIO VESSEL	LG CHEMICAL	GERMANY	2024
FOOD PRODUCE SYSTEM	AUTO CLAVE / BIO VESSEL	CJ	FRANCE	2024
UT PROJECT	AIR HEADERS FOR SEWAGE TREATMENT	GUNSAN SEWAGE TREATMENT CENTER	KOREA	2024
OXO SUPER	HEATER	LG CHEM.	KOREA	2024
BIO SYSTEM	PROCESS VESSEL / CYCLONE	LOTTE BIO	FRANCE	2024
VHE PROJECT	CONDENSER	CGP MATERIALS	KOREA	2024
SI2H6 PROJECT	SI2H6 RESIDUAL GAS PURIFICATION EQUIPMENT	SOLEMATERIALS	KOREA	2024
PAPER PRODUCE SYSTEM	DRYER	AJIN P&P	CHINA	2024
LNG TERMINAL PROJECT	DRYER / FILTER	POSCO E&C	KOREA	2024
SHAHEEN PROJECT	STORAGE TANK	S-OIL CORP.	KOREA	2024
GAS PRODUCE SYSTEM	HEAT EXCHANGER	ENF	CHINA	2024
PHARMACY SYSTEM	H/EX / SEPARATOR	JANSSEN	GERMANY	2024
A180 PROJECT	HELIUM GAS PURIFICATION GETTER TOWER	SAMSUNG SDI	KOREA	2024
JIO-PROJECT	DRYER / REACTOR	JIOS AEROGEL	SINGAPORE	2024
BIOGAS UPGRADING SYSTEM	TOWER / BIO VESSEL	ECO BIO	KOREA	2024
SECONDARY CELL	PRESSURE VESSEL	POSCO	GERMANY	2024
GL-R PROJECT	MEDICAL DEVICE MANUFACTURING EQUIPMENT	META BIOMED	KOREA	2024
BIO DIESEL PROJECT	EVAPORATOR / DRYER / CONDENSER	GS BIO	KOREA	2024

NAME OF PROJECT	DESCRIPTION	CLIENT	SITE	YEAR
NUCLEAR FUEL TEST FACILITY	TOWER / VESSEL	KEPCO NUCLEAR FUEL	KOREA	2025
GL PJT	SURGICAL SUTURE MANUFACTURING EQUIPMENT	META BIOMED	KOREA	2025
FOOD PRODUCE SYSTEM	AUTO CLAVE	LOTTE FOOD	FRANCE	2025
JNPP PROJECT	DRYER	HS BIO	KOREA	2025
XLP PJT	CHEMICAL & PHYSICAL ADSORPTION COLUMN	SAMSUNG	KOREA	2025
CHEMICAL SYSTEM	GL REACTOR	MIJOO	CHINA	2025
HP PROJECT	NITROGEN PURIFICATION SYSTEM	WOORIM	KOREA	2025
BIO SYSTEM	HEAT EXCHANGER	GREEN CROSS	CHINA	2025
CIS-PROJECT	MIXING TANK	CIS CHEMICAL	KOREA	2025
EUV THINNER	REACTOR / CONDENSER / RECEIVER TANK	CHEMTROS	KOREA	2025
SECONDARY CELL	PRESSURE VESSEL	POSCO	GERMANY	2025
CHEMICAL SYSTEM	EVAPORATOR	SGC	CHINA	2025
ELECTRIC PROVIDING SYSTEM	PRESSURE VESSEL	LS ELECTRIC	GERMANY	2025
BIO SYSTEM	HEAT EXCHANGER	BIO POUR	CHINA	2025
SHORT PATH DISTILLATOR	DISTILLATOR /	SK CHEMICAL	KOREA	2025
O2 AD PJT	HIGH-PRESSURE OXYGEN DECOMPOSITION COLUMN	SAMSUNG	KOREA	2025
R-101 PJT	PYROLYSIS & CRYSTALLIZATION REACTORS	META BIOMED	KOREA	2025
D PROJECT	LNG HIGH-PRESSURE CYLINDER	HD HYDROGEN	KOREA	2025
DEEP OCEAN WATER PRODUCE SYSTEM	REACTOR	COOP ENG	CHINA	2025
1HAPL PICKLING PROJECT	LOW-PRESSURE HYDROGEN EQUIPMENT	POSCO	KOREA	2025
CHEMICAL SYSTEM	PROCESS VESSEL	LG CHEMICAL	MALAYSIA	2025
BIO SYSTEM	BIO VESSEL	SAMSUNG BIO	FRANCE	2025
ABN-PROJECT	HEATER	ALBANY INTERNATIONAL	USA	2025
K-CALL PROJECT	H/EX / REACTOR	WELKIN BIOTECHNOLOGY	CHINA	2025
RS-101 PROJECT	HIGH-CONCENTRATION SLURRY REACTOR	EcoPro BM	KOREA	2025
PROCESS DRINK PRODUCE SYSTEM	PRESSURE VESSEL	GAONNURI	CHINA	2025
PS PROJECT	PURE STEAM GENERATION SYSTEM	DALIMBIOTECH	KOREA	2025
BIO SYSTEM	HEAT EXCHANGER	BINEX	ITALY	2025
PAPER PRODUCE SYSTEM	DRYER	MOORIM P & P	ITALY	2025
H2 PROJECT	LOW-PRESSURE HYDROGEN SYSTEM	TAEGUTECH	KOREA	2025
MEDICAL EQUIPMENT SYSTEM	CHAMBER	CYTIVA	UK	2025

NAME OF PROJECT	DESCRIPTION	CLIENT	SITE	YEAR
INCINERATION FACILITY	REACTOR / DRYER	ANSAN CITY	KOREA	2025
HEXA 1500 L/H	HEXA MIXER	SAMSUNG ELECTRONICS	KOREA	2025
NH3 Recovery PROJECT	AMMONIA RECOVERY & PURIFICATION SYSTEM	RIST	KOREA	2025
CHEMICAL SYSTEM	GL REACTOR	SDC	CHINA	2025
H1 PLANT	HEAT EXCHANGER	KCC CORP.	KOREA	2025
Sapphire Modify PROJECT	LAB CHEMICAL SYSTEM MAINTENANCE UNIT	PKC	KOREA	2025
BIO SYSTEM	REACTOR	SK BIO	USA	2025
MEDICAL EQUIPMENT SYSTEM	CHAMBER	AJOO UNIVERSITY HOSPITAL	ITALY	2025
CDQ PROJECT	CDQ BOILER	POSCO	KOREA	2025
DEG PROJECT	DEG PRESSURE VESSEL	SAMYANG HOLDINGS CORP.	KOREA	2025
HW PROJECT	MIXER BOWL	HANWHA AEROSPACE	KOREA	2025
H2 PSA SYSTEM	HIGH-PURITY HYDROGEN PURIFICATION SYSTEM	HYUNDAI MOTOR COMPANY	KOREA	2025
RECHARGEABLE BATTERY	HEAT EXCHANGER	SUNG HIMETAL	CHINA	2025
SLUDGE TREATMENT SYSTEM	DRYER	BUCHEON CITY	KOREA	2025
FOOD PRODUCE SYSTEM	BIO VESSEL	LOTTE WELL FOOD	SWISS	2025
SECONDARY CELL	VESSEL	POSCO PLANTEC	INDIA	2025
DCD PROJECT	MELT POLYMERIZATION REACTOR	META BIOMED	KOREA	2025
GAS PROVIDING SYSTEM	PROCESS VESSEL	ISTE	CHINA	2025
P PROJECT	PRESSURE TANK	POSCO	KOREA	2025
PRSTG	H/EX / EVAPORATOR / TANK	PRESTIGE BIOLOGICS	KOREA	2025
CDQ3 PROJECT	DUST COLLECTING & COOLING SYSTEM	POSCO	KOREA	2025
PHARMACY RESEARCH SYSTEM	HEAT EXCHANGER	CHUNGANG VACCINE	GERMANY	2025
FOOD PRODUCE SYSTEM	PROCESS VESSEL	DONGWON FOOD	FRANCE	2025
GREEN STEAM POWER PROJECT	CONDENSER / H/EX	MOORIM P&P	KOREA	2025
BF3 CLEANING SYSTEM	BF3 FROM 11BF3 SCRUBBING & DECONTAMINATION SYSTEM	TEMC	KOREA	2025
PROCESS MILK SYSTEM	PROCESS VESSEL	BINGGRAE	GERMANY	2025
FOOD PEELER SYSTEM	BOILER & STEAM PEELER	AGRICULTURAL CORPORATION	TURKIYE	2025
SOLID PROJECT	HEAT EXCHANGER	KIER	KOREA	2025
SORTER PROJECT	H/EX / CYCLONE	SAMSUNG SDI	KOREA	2025
Ar PROJECT	ARGON GAS STORAGE TANK	WOORIM	KOREA	2025
1HAPL PICKLING PROJECT	HEAT EXCHANGER	POSCO	KOREA	2025

PARTNER WITH SEOEUN PLANT TECH



공식 홈페이지



공식 블로그



공식 카탈로그



서은플랜트기술(주)
SEOEUN PLANT TECH CO., LTD.

분당센터

경기도 성남시 분당구 정자일로 1, C동 1412호

보은센터

충청북도 보은군 삼승면 남부로 3750-235

화성센터

경기도 화성시 팔탈면 노하길 347-15

문의전화 010-7760-6176 / 010-5796-2389 대표전화 031-703-0480

홈페이지 www.seplant.com 이메일 septech@septech.co.kr 팩스 031-703-0481